

Operating Instructions

Artis 170
Artis 210

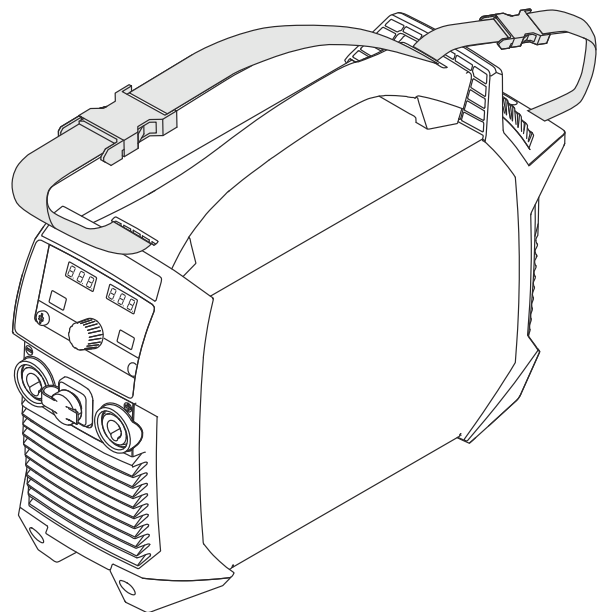

EN-US | Operating instructions



42,0426,0516,EA

003-06122024

Table of contents

Safety Instructions	6
Explanation of Safety Instructions	6
General.....	6
Intended Use	7
Environmental Conditions.....	7
Obligations of the Operating Company.....	7
Obligations of Personnel.....	7
Grid Connection.....	8
Residual current circuit breaker	8
Personal Protection and Protection of Others.....	8
Data on noise emission values.....	9
Danger from toxic gases and vapors.....	9
Danger from Flying Sparks.....	9
Risks from mains current and welding current.....	10
Stray welding currents	11
EMC Device Classifications.....	11
EMC measures.....	11
EMF measures.....	12
Particular hazard areas.....	12
Requirement for the shielding gas.....	13
Danger from Shielding Gas Cylinders	13
Danger Posed by Shielding Gas Leak.....	14
Safety Measures at the Setup Location and during Transport.....	14
Safety Measures in Normal Operation	15
Maintenance and repair.....	15
Safety inspection.....	16
Disposal.....	16
Safety symbols.....	16
Data backup.....	17
Copyright.....	17
General information	19
General.....	21
Device concept.....	21
Operating principle	21
Application areas.....	21
Remote control operating mode.....	22
Warning notices on the device.....	22
Operating controls and connections	25
Control Panel.....	27
General.....	27
Safety	27
Control panel.....	27
Connections, Switches, and Mechanical Components.....	32
Operating Controls, Connections, and Mechanical Components.....	32
Installation and Startup	33
Minimum equipment for welding operations	35
General.....	35
TIG DC welding.....	35
MMA welding	35
Before installation and initial operation.....	36
Safety	36
Intended use.....	36
Setup Regulations.....	36
Grid Connection.....	36
Generator-powered operation.....	37

Connecting the Mains Cable.....	38
General.....	38
Safety.....	38
Connecting the mains cable.....	38
Commissioning.....	39
Safety.....	39
General.....	39
Connecting the Gas Cylinder.....	39
Connecting the welding torch to the welding system.....	40
Establishing a Ground Earth Connection with the Workpiece.....	41
Measuring the welding circuit resistance "r".....	41
Welding Mode	43
TIG Operating Modes.....	45
Safety.....	45
Symbols and explanations.....	46
2-Step Mode.....	47
4-Step Mode.....	47
Spot Welding.....	48
TIG welding.....	49
Safety.....	49
Preparation.....	49
TIG welding.....	50
Welding parameters.....	51
Igniting the arc.....	53
Igniting the arc using high frequency(HF ignition).....	53
Contact ignition for welding torch with torch trigger.....	54
Contact ignition for welding torch without torch trigger.....	56
Igniting the arc using high-frequency contact(Touch-HF).....	57
Overloading of the tungsten electrode.....	57
End of Welding.....	57
Special functions.....	58
Arc break monitoring function.....	58
Ignition Time-Out.....	58
TIG pulsing.....	58
Tacking function.....	59
Manual Metal Arc Welding.....	61
Safety.....	61
Preparation.....	61
MMA welding.....	62
Manual Metal Arc Welding with Cel Electrodes.....	62
Pulse welding.....	62
Starting current > 100% (HotStart).....	64
Starting current < 100% (SoftStart).....	64
Anti-stick function.....	65
Setup Settings	67
The Setup Menu.....	69
General.....	69
Accessing the Setup Menu.....	69
Adjusting Parameters.....	70
Overview.....	70
TIG Setup Menu.....	71
Parameters in the TIG Setup menu.....	71
Parameters in the TIG - 2nd level Setup menu.....	74
Parameters in the 2nd level Setup menu.....	78
Rod Electrode Setup Menu.....	81
Parameters in the stick electrode Setup menu.....	81
Troubleshooting and Maintenance	85
Troubleshooting.....	87

General.....	87
Safety	87
Displayed Faults.....	87
Service messages	88
No Function.....	89
Inadequate function	90
Service, maintenance and disposal	92
General.....	92
Safety	92
At every start-up.....	92
Maintenance every two months.....	93
Disposal.....	93

Appendix 95

Average consumption values during welding.....	97
Average shielding gas consumption during TIG welding	97
Technical data.....	98
Special Voltage.....	98
Artis 170 EF, Artis 170 np	98
Artis 170 XT/B, Artis 170 XT/np	100
Artis 210 EF, Artis 210 np	102
Artis 210 XT/B, Artis 210 XT/np	104
Explanation of footnotes	105
Overview with critical raw materials, year of production of the device.....	107

Safety Instructions

Explanation of Safety Instructions

DANGER!

Indicates an immediate danger.

- ▶ Death or serious injury may result if appropriate precautions are not taken.
-

WARNING!

Indicates a possibly dangerous situation.

- ▶ Death or serious injury may result if appropriate precautions are not taken.
-

CAUTION!

Indicates a situation where damage or injury could occur.

- ▶ Minor injury or damage to property may result if appropriate precautions are not taken.
-

NOTE!

Indicates the possibility of flawed results and damage to the equipment.

General

The device has been manufactured using state-of-the-art technology and according to recognized safety standards. If used incorrectly or misused, however, it can cause

- Injury or death to the operator or a third party
 - Damage to the device and other material assets belonging to the operating company
 - Inefficient operation of the equipment
-

All persons involved in the commissioning, operation, maintenance, and servicing of the device must

- Be suitably qualified
 - Have knowledge of welding
 - Have completely read and followed these Operating Instructions
-

The Operating Instructions must always be at hand wherever the device is being used. In addition to the Operating Instructions, all applicable local rules and regulations regarding accident prevention and environmental protection must also be followed.

All safety and danger notices on the device must

- Be kept in a legible state
 - Not be damaged/marked
 - Not be removed
 - Not be covered, pasted, or painted over
-

For the location of the safety and danger notices on the device, refer to the section headed "General" in the Operating Instructions for the device.

Before switching on the device, remove any faults that could compromise safety.

Your personal safety is at stake!

Intended Use

The device is to be used exclusively for its intended purpose.

The device is intended exclusively for the welding process specified on the rating plate.

Utilization for any other purpose, or in any other manner, shall be deemed to be "not in accordance with the intended purpose." The manufacturer is not responsible for any damage resulting from improper use.

Proper use also means

- Completely reading and obeying all instructions in the Operating Instructions
- Completely reading and obeying all safety instructions and danger notices
- Carrying out all the specified inspection and servicing work

Never use the device for the following applications:

- Thawing pipes
- Charging batteries
- Starting motors

The device is designed for operation in industry and business. The manufacturer shall not be liable for any damage resulting from use in a living area.

The manufacturer shall also not be liable for faulty or incorrect work results.

Environmental Conditions

Operation or storage of the device outside the stipulated area will be deemed as not in accordance with the intended purpose. The manufacturer accepts no liability for any damage resulting from improper use.

Temperature range of the ambient air:

- During operation: -10°C to +40°C (14°F to 104°F)
- During transport and storage: -20°C to +55°C (-4°F to 131°F)

Relative humidity:

- Up to 50% at 40°C (104°F)
- Up to 90% at 20°C (68°F)

Ambient air: free of dust, acids, corrosive gases or substances, etc.

Altitude above sea level: up to 2000 m (6561 ft. 8.16 in.)

Obligations of the Operating Company

- The operating company must only allow persons to work with the device if they
- Are familiar with the basic occupational safety and accident prevention regulations and are trained in handling the device
 - Have read and understood these Operating Instructions, especially the section "Safety Rules," and have confirmed this with their signature
 - Are trained according to the requirements for the work results

The safety-conscious work of the personnel must be checked regularly.

Obligations of Personnel

All persons who are assigned to work with the device must do the following before beginning the work:

- Follow the basic regulations for occupational safety and accident prevention
- Read these Operating Instructions, especially the section "Safety Rules," and confirm that they have understood and will follow them by signing

Before leaving the workplace, ensure that no personal injury or property damage can occur in one's absence.

Grid Connection Devices with a high output can influence the energy quality of the grid due to their current consumption.

This may affect a number of device types in terms of:

- connection restrictions
- criteria regarding maximum permissible grid impedance ^{*)}
- criteria regarding the minimum required short-circuit power ^{*)}

^{*)} both at the interface with the public grid

See technical data

In this case, the operator or the person using the device should check whether or not the device is allowed to be connected, where appropriate through discussion with the power supply company.

IMPORTANT! Ensure secure grounding of the grid connection!

Residual current circuit breaker Local regulations and national guidelines may mean that a residual current circuit breaker is required when connecting a device to the public grid. The residual current circuit breaker recommended for the device by the manufacturer can be found in the technical data.

Personal Protection and Protection of Others You are exposed to numerous hazards while handling the device, for example:

- Flying sparks and pieces of hot metal
- Arc radiation that poses a risk of injury to the eyes and skin
- Hazardous electromagnetic fields that pose a risk of death for individuals with pacemakers
- Electrical risks from grid current and welding current
- Increased noise exposure
- Harmful welding fumes and gases

Wear suitable protective clothing when dealing with the device. The protective clothing must have the following properties:

- Flame resistant
 - Insulating and dry
 - Covering the entire body and in good condition with no damage
 - Safety helmet
 - Cuffless pants
-

Protective clothing involves the following:

- Protecting the face and eyes from UV radiation, heat and flying sparks with a face guard featuring a regulation-compliant filter
 - Wearing regulation-compliant protective goggles with side protection behind the face guard
 - Wearing rigid, wet-insulating footwear
 - Protecting hands with appropriate gloves (featuring electrical insulation and thermal protection)
 - Wearing ear protection to reduce noise exposure and protect against injury
-

Keep persons, especially children, away during the operation of the devices and during the welding process. If persons are in the vicinity, however:

- Instruct them about all hazards (blinding hazard due to arcs, risk of injury from flying sparks, welding fumes hazardous to health, noise exposure, possible hazard due to grid current or welding current, etc.)
- Provide suitable protective equipment or
- Construct suitable protective walls and curtains.

Data on noise emission values

The device produces a maximum noise level of <80 dB(A) (ref. 1pW) when idling and in the cooling phase following operation in relation to the maximum permitted operating point at standard loading in accordance with EN 60974-1.

A workplace-specific emission value for welding (and cutting) cannot be specified because this value depends on the welding process and the environmental conditions. It is influenced by a wide range of parameters, such as the welding process itself (MIG/MAG, TIG welding), the selected current type (direct current, alternating current), the power range, the type of weld metal, the resonance properties of the workpiece, the workplace environment, and many other factors.

Danger from toxic gases and vapors

The fumes produced during welding contain toxic gases and vapors.

Welding fumes contain substances that cause cancer, as stated in monograph 118 from the International Agency for Research on Cancer.

Use at-source extraction source and a room extraction system.
If possible, use a welding torch with an integrated extraction device.

Keep your head out of the welding fumes and gases.

Take the following precautionary measures for fumes and harmful gases:

- Do not breathe them in.
- Extract them from the work area using appropriate equipment.

Ensure that there is a sufficient supply of fresh air. Ensure that there is a ventilation flow rate of at least 20 m³ per hour.

Use a welding helmet with air supply if there is insufficient ventilation.

If there is uncertainty as to whether the extraction capacity is sufficient, compare the measured toxic emission values against the permissible limit values.

The following components are factors that determine how toxic the welding fumes are:

- The metals used for the workpiece
- Electrodes
- Coatings
- Cleaning agents, degreasers, and the like
- The welding process used

Consult the corresponding material safety data sheets and manufacturer's instructions for the components listed above.

Recommendations for exposure scenarios, risk management measures and identifying working conditions can be found on the European Welding Association website under Health & Safety (<https://european-welding.org>).

Keep flammable vapors (such as solvent vapors) out of the arc radiation range.

When no welding is taking place, close the valve of the shielding gas cylinder or the main gas supply.

Danger from Flying Sparks

Flying sparks can cause fires and explosions.

Never undertake welding near flammable materials.

Flammable materials must be kept at least 11 meters (36 ft. 1.07 in.) from the arc or protected with a certified cover.

Keep suitable, tested fire extinguishers on hand.

Sparks and pieces of hot metal may also get into surrounding areas through small cracks and openings. Take appropriate measures to ensure that there is no risk of injury or fire.

Do not undertake welding in areas at risk of fire and explosion, or on sealed tanks, drums, or pipes if these have not been prepared in accordance with corresponding national and international standards.

Do not undertake welding on containers in which gases, fuels, mineral oils, and the like are/were stored. Residues pose a risk of explosion.

Risks from mains current and welding current

An electric shock can be fatal.

Do not touch voltage-carrying parts inside or outside the device.

During MIG/MAG welding and TIG welding, the welding wire, the wire spool, the feed rollers, as well as all pieces of metal that are in contact with the welding wire, are live.

Always place the wirefeeder on a sufficiently insulated base or use a suitable insulating wirefeeder holder.

Ensure suitable personal protection with dry temporary backing or cover with sufficient insulation against the ground potential. The temporary backing or cover must completely cover the entire area between the body and the ground potential.

All cables and leads must be secured, undamaged, insulated, and adequately dimensioned. Replace loose connections and scorched, damaged, or inadequately dimensioned cables and leads immediately.

Before every use, check power connections for secure fit by hand.

In the case of power cables with bayonet connectors, turn the power cable by at least 180° around the longitudinal axis and pretension.

Do not wrap cables or leads around your body or parts of the body.

Concerning the electrode (stick electrode, tungsten electrode, welding wire, etc.)

- Never immerse it in liquids to cool it
 - Never touch it when the welding system is switched on
-

The open circuit voltage of a welding system may double, for example, between the electrodes of two welding systems. Touching the potentials of both electrodes at the same time may be life-threatening in some cases.

Have the grid and device supply lead regularly inspected by an electrician to ensure that the ground conductor is functioning properly.

Protection class I devices require a grid with a ground conductor and a connector system with ground conductor contact for proper operation.

Operation of the device on a grid without a ground conductor and on a socket without a ground conductor contact is only permitted if all national regulations for protective separation are observed.

Otherwise, this is considered gross negligence. The manufacturer accepts no liability for any damage resulting from improper use.

Use suitable equipment to ensure that the workpiece is sufficiently grounded if necessary.

Switch off unused devices.

When working at elevated heights, wear a safety harness to prevent falls.

Before working on the device, switch off the device and remove the mains plug.

Secure the device to prevent the mains plug from being connected and switched on again by applying a clearly legible and understandable warning sign.

After opening the device:

- Discharge all electrically charged components
 - Ensure that all components are disconnected from the power supply
-

If work is needed on voltage-carrying parts, bring in a second person who will switch off the main switch at the correct time.

Stray welding currents

If the following instructions are not observed, stray welding currents may occur, which pose a risk of the following:

- Fire
 - Overheating of parts connected to the workpiece
 - Irreparable damage to ground conductors
 - Damage to the device and other electrical equipment
-

Ensure that the workpiece clamp is securely connected to the workpiece.

Secure the workpiece clamp as close to the spot to be welded as possible.

Position the device with sufficient insulation against electrically conductive environments, e.g., insulation against electrically conductive floors or electrically conductive mounts.

Observe the following when using power distribution boards, twin-head mounts, etc.: Even the electrode of the welding torch/electrode holder not in use carries electric potential. Ensure that there is sufficient insulation when the unused welding torch/electrode holder is stored.

In automated MIG/MAG applications, only guide the wire electrode from the welding wire drum, large spool, or wirepool to the wirefeeder with insulation.

EMC Device Classifications

Devices in emission class A:

- Are only designed for use in industrial settings
 - Can cause line-bound and radiated interference in other areas
-

Devices in emission class B:

- Satisfy the emissions criteria for residential and industrial areas. This is also true for residential areas in which the energy is supplied from the public low-voltage grid.
-

EMC device classification as per the rating plate or technical data.

EMC measures

In certain cases, even though a device complies with the standard limit values for emissions, it may affect the application area for which it was designed (e.g., when there is sensitive equipment at the same location, or if the site where the device is installed is close to either radio or television receivers).

If this is the case, then the operating company is obliged to take appropriate action to rectify the situation.

Test and assess the immunity of equipment in the vicinity of the device in accordance with national and international provisions. Examples of interference-prone equipment that could be affected by the device:

- Safety devices
 - Grid power lines, signal lines, and data transfer lines
 - IT and telecommunications equipment
 - Devices for measuring and calibrating
-

Supporting measures to avoid EMC problems:

1. Grid power supply
 - If electromagnetic interference occurs despite a grid connection that complies with regulations, take additional measures (e.g., use a suitable grid filter).
 2. Welding power-leads
 - Keep them as short as possible
 - Route them close together (also to avoid EMF problems)
 - Route them far from other lines
 3. Equipotential bonding
 4. Workpiece grounding
 - If necessary, establish grounding using suitable capacitors.
 5. Shield, if necessary
 - Shield other devices in the vicinity
 - Shield the entire welding installation
-

EMF measures

Electromagnetic fields may cause health problems that are not yet known:

- Effects on the health of persons close by, e.g., those with pacemakers and hearing aids
 - Persons with pacemakers must seek advice from their doctor before staying in the immediate vicinity of the device and the welding process
 - Keep distances between welding power-leads and the head/torso of the welder as great as possible for safety reasons
 - Do not carry welding power-leads and hosepacks over your shoulder or wrap them around your body or body parts
-

Particular hazard areas

Keep hands, hair, loose clothing, and tools away from moving parts, such as:

- Fans
 - Gears
 - Rollers
 - Shafts
 - Wire spools and welding wires
-

Do not reach into rotating gears of the wire drive or into rotating drive parts.

Covers and side panels must only be opened/removed during maintenance and repair work.

During operation

- Ensure that all covers are closed, and all side parts have been mounted properly.
 - Keep all covers and side parts closed.
-

The protrusion of welding wire from the welding torch represents a high risk of injury (cuts to the hand, facial and eye injuries, etc.).

Therefore, always hold the welding torch away from the body (devices with wirefeeder) and use suitable protective goggles.

Do not touch the workpiece during or after welding – risk of burns.

Slag may fly off cooling workpieces. Therefore, also wear regulation-compliant protective equipment when reworking workpieces and ensure that other persons are sufficiently protected.

Leave the welding torch and other parts with a high operating temperature to cool before working on them.

Special regulations apply in areas at risk of fire or explosion
– follow the appropriate national and international regulations.

Welding systems for work in areas with increased electrical hazard (e.g., boilers) must be labeled with the symbol (Safety). However, the welding system may not be located in such areas.

Risk of scalding due to leaking coolant. Switch off the cooling unit before disconnecting connections for the coolant supply or return.

When handling coolant, observe the information on the coolant safety data sheet. The coolant safety data sheet can be obtained from your service center or via the manufacturer's website.

In the event of crane attachment of the wirefeeder during welding, always use a suitable, insulating wirefeeder hoisting attachment (MIG/MAG and TIG devices).

If the device is equipped with a carrier belt or handle, then this is used exclusively for transport by hand. The carrier belt is not suitable for transport by crane, counterbalanced lift truck, or other mechanical lifting tools.

All lifting equipment (belts, buckles, chains, etc.), which is used in association with the device or its components, must be checked regularly (e.g., for mechanical damage, corrosion, or changes due to other environmental influences). The test interval and scope must at least comply with the respective valid national standards and guidelines.

There is a risk of colorless, odorless shielding gas escaping without notice if an adapter is used for the shielding gas connection. Use suitable Teflon tape to seal the thread of the shielding gas connection adapter on the device side before installation.

Requirement for the shielding gas

Especially with ring lines, contaminated shielding gas can cause damage to equipment and reduce welding quality.

Meet the following requirements regarding shielding gas quality:

- Solid particle size < 40 µm
 - Pressure condensation point < -20 °C
 - Max. oil content < 25 mg/m³
-

Use filters if necessary.

Danger from Shielding Gas Cylinders

Shielding gas cylinders contain compressed gas and may explode if damaged. Shielding gas cylinders are an integral part of the welding equipment, so they must be handled very carefully.

Protect shielding gas cylinders with compressed gas from excessive heat, mechanical impact, slag, open flames, sparks, and arcs.

Mount the shielding gas cylinders vertically and secure them in accordance with instructions so they cannot fall over.

Keep shielding gas cylinders away from welding or other electrical circuits.

Never hang a welding torch on a shielding gas cylinder.

Never touch a shielding gas cylinder with an electrode.

Risk of explosion: Never weld on a compressed shielding gas cylinder.

Always use suitable shielding gas cylinders for the application in question and the correct matching accessories (controller, hoses, and fittings, etc.) Only use shielding gas cylinders and accessories that are in good condition.

If a valve on a shielding gas cylinder is open, turn your face away from the outlet.

When no welding is taking place, close the valve of the shielding gas cylinder.

Leave the cap on the valve of the shielding gas cylinder when the cylinder is not connected.

Follow the manufacturer's instructions and applicable national and international provisions for shielding gas cylinders and accessories.

Danger Posed by Shielding Gas Leak

Risk of asphyxiation due to uncontrolled shielding gas leak

Shielding gas is colorless and odorless and may suppress the oxygen in the ambient air in the event of leakage.

- Ensure there is a sufficient supply of fresh air with a ventilation flow rate of at least 20 m³ per hour.
 - Please observe the safety and maintenance information for the shielding gas cylinder or the main gas supply.
 - When no welding is taking place, close the valve of the shielding gas cylinder or the main gas supply.
 - Always check the shielding gas cylinder or main gas supply for uncontrolled gas leakage before each start-up.
-

Safety Measures at the Setup Location and during Transport

A toppling device can be deadly! Set up the device securely on an even, solid surface

- The maximum permitted tilt angle is 10°.
-

Special regulations apply in areas at risk of fire or explosion

- Follow the appropriate national and international regulations.
-

Use instructions and checks within the company to ensure that the vicinity of the workplace is always clean and organized.

Only set up and operate the device in accordance with the protection class shown on the rating plate.

When setting up the device, ensure that there is an all-round clearance of 0.5 m (1 ft. 7.69 in.) to allow cooling air to circulate unhindered.

Take care to ensure that the applicable national and regional guidelines and accident prevention regulations are observed when transporting the device, especially guidelines concerning hazards during transport and shipment.

Do not lift or transport any active devices. Switch off and disconnect devices from the grid before transport or lifting.

Before transporting a welding system (e.g., with a trolley, cooling unit, welding machine, and wirefeeder), completely drain the coolant and dismantle the following components:

- Wirefeeder
- Wire spool
- shielding gas cylinder

It is essential to conduct a visual inspection of the device to check for damage after it has been transported but before commissioning. Have any damage repaired by trained service technicians before commissioning the device.

Safety Measures in Normal Operation

Only operate the device when all safety devices are fully functional. If the safety devices are not fully functional, there is a danger of:

- Injury or death to the operator or a third party
- Damage to the device and other material assets belonging to the operating company
- Inefficient operation of the device

Safety devices that are not fully functional must be repaired before the device is switched on.

Never bypass or disable safety devices.

Before switching on the device, ensure that no one can be put in danger.

The device must be examined at least once a week for externally detectable damage and functionality of the safety devices.

Always secure the shielding gas cylinder well and remove before transporting by crane.

Only the original coolant from the manufacturer is suitable for use in our devices due to its properties (electrical conductivity, anti-freeze, material compatibility, flammability, etc.)

Only use appropriate original coolant from the manufacturer.

Do not mix original coolant from the manufacturer with other coolants.

Only connect system components from the manufacturer to the cooling unit circuit.

If there is damage due to use of other system components or other coolants, the manufacturer accepts no liability for this and all warranty claims are forfeited.

Cooling Liquid FCL 10/20 is not flammable. The ethanol-based coolant is flammable in certain conditions. Only transport the coolant in closed original containers and keep away from sources of ignition.

Properly dispose of used coolant according to national and international regulations. The coolant safety data sheet can be obtained from your service center or via the manufacturer's website.

When the system is cool, always check the coolant level before starting welding.

Maintenance and repair

It is impossible to guarantee that bought-in parts are designed and manufactured to meet the demands made of them, or that they satisfy safety requirements.

- Use only original spare and wearing parts (also applies to standard parts).
- Do not carry out any modifications, alterations, etc. to the device without the manufacturer's consent.
- Components that are not in perfect condition must be replaced immediately.
- When ordering, please give the exact designation and part number as shown in the spare parts list, as well as the serial number of your device.

The housing screws provide the ground conductor connection for earthing the housing parts.

Only use original housing screws in the correct number and tightened to the specified torque.

Safety inspection

The manufacturer recommends that a safety inspection of the device be performed at least every 12 months.

The manufacturer recommends calibrating welding systems within the same 12-month interval.

A safety inspection by a certified electrician is recommended:

- After changes
- After alterations
- After repair, service, and maintenance
- At least every twelve months

For the safety inspection, follow the appropriate national and international standards and guidelines.

You can obtain more information about the safety inspection and calibration from your service center. The service center will provide the necessary documents upon request.

Disposal

Waste electrical and electronic equipment must be collected separately and recycled in an environmentally sound manner in accordance with the European Directive and national law. Used equipment must be returned to the distributor or through a local authorized collection and disposal system. Proper disposal of the used device promotes sustainable recycling of resources and prevents negative effects on health and the environment.

Packaging materials

- Collect separately
- Observe local regulations
- Crush cardboard boxes

Safety symbols

Devices with the CE label satisfy the essential requirements of the low-voltage and electromagnetic compatibility directive (e.g., relevant product standards of the EN 60974 series).

Fronius International GmbH declares that the device complies with Directive 2014/53/EU. The full text of the EU Declaration of Conformity is available on the following website: <http://www.fronius.com>

Devices marked with the CSA test mark satisfy the requirements of the relevant standards for Canada and the USA.

Data backup

- With regard to data security, the user is responsible for:
- backing up any changes made to the factory settings
 - saving and storing personal settings

Copyright

Copyright of these operating instructions remains with the manufacturer.

Text and illustrations were accurate at the time of printing, subject to change.
We are grateful for suggestions for improvement and information on any discrepancies in the operating instructions.

General information

General

Device concept

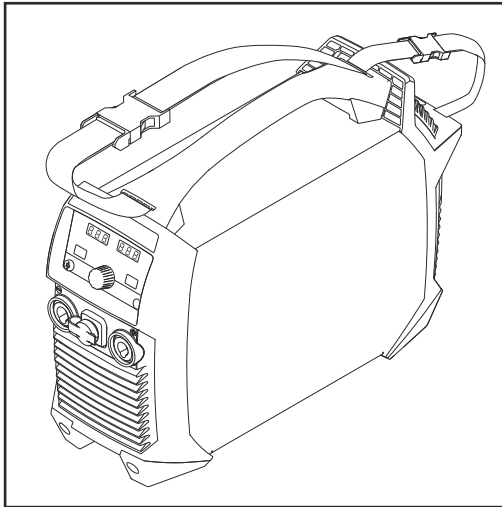

The Artis 170 and Artis 210 TIG welding systems are microprocessor-controlled inverter power sources.

A modular design and easy ability to extend the system guarantee a high degree of flexibility.

The welding systems are generator-compatible and are equipped with protected operating elements and a robust plastic housing.

As a result of the simple operating concept, key functions can be quickly viewed and adjusted.

The welding systems can also be operated via the standard TIG Multi Connector with various remote controls or an Up/Down torch.

The TIG pulsed arc function means that the welding systems offer a wide frequency range.

Additionally, the welding systems offer "Power Factor Correction", meaning the current consumption of the welding system adapts to the sinusoidal mains voltage. This results in advantages such as:

- Low primary current
- Low conductivity losses
- Late tripping of the automatic circuit breaker
- Improved stability during voltage fluctuations
- Compatibility with long mains leads
- Consistent input voltage range with multivoltage devices

Operating principle

The central control unit of the welding system controls the entire welding process.

During the welding process, actual values are continually measured and the device immediately responds to any changes. Rule algorithms ensure that the desired target state is maintained.

This results in:

- A precise welding process
- A high degree of reproducibility of all results
- Excellent weld properties

Application areas

The welding systems can be used in repair and maintenance for production and manufacturing tasks.

Remote control operating mode

The Artis 170 and Artis 210 welding systems can be operated using the following remote controls:

- RC Bar 1P
- RC Panel MMA
- RC Pedal TIG
- RC Panel Basic TIG

Warning notices on the device

Warning notices and safety symbols can be found on welding systems with the CSA test mark for use in the North American region (USA and Canada). These warning notices and safety symbols must not be removed or painted over. They warn against incorrect operation, as this may result in serious injury and property damage.

⚠ WARNING	⚠ AVERTISSEMENT
Do Not Remove, Destroy, or Cover This Label	Ne pas retirer, détruire ni couvrir cette étiquette
<p>PROTECT yourself and others. ARC PROCESSES can be hazardous.</p> <ul style="list-style-type: none"> • Before use, read and follow all labels, the manufacturer's instruction manual, employer's safety practices, and Material Safety Data Sheets (MSDS). • Only qualified persons are to install, use, or service this equipment. • Pacemaker wearers keep away. • Damaged or modified batteries may exhibit unpredictable behaviour resulting in fire, explosion or risk of injury. <p>ELECTRIC SHOCK can kill.</p> <ul style="list-style-type: none"> • Do not touch live electrical parts. • Always wear dry insulating gloves. • Insulate yourself from work and ground. • Disconnect input power before servicing unit. • Welding wire and drive parts may be at welding voltage. <p>FUMES AND GASES can be hazardous to your health.</p> <ul style="list-style-type: none"> • Keep your head out of the fumes. • Use enough ventilation, exhaust at the arc, or both to keep fumes and gases from your breathing zone and the general area. • Under abusive conditions, liquid may be ejected from the battery, avoid contact. <p>SPARKS AND SPATTER can cause fire or explosion.</p> <ul style="list-style-type: none"> • Do not use near flammable material. • Do not use on closed containers. <p>ARC RAYS can injure eyes and burn skin. NOISE can damage hearing.</p> <ul style="list-style-type: none"> • Wear correct eye, ear, and body protection. 	<p>SE PROTÉGER et protéger les autres. Les PROCÉDES À L'ARC ELECTRIQUE peuvent être dangereux.</p> <ul style="list-style-type: none"> • Avant utilisation, lire et respecter l'ensemble des étiquettes, les instructions de service du fabricant, les pratiques de sécurité de l'employeur et les fiches techniques de sécurité du matériel. • Seules des personnes qualifiées sont autorisées à installer, utiliser ou assurer l'entretien de cet équipement. • Les personnes portant un stimulateur cardiaque doivent rester à l'écart. • Les batteries endommagées ou modifiées peuvent avoir un comportement imprévisible susceptible de provoquer un incendie, une explosion ou un risque de blessure. <p>Les DÉCHARGES ÉLECTRIQUES peuvent être mortelles.</p> <ul style="list-style-type: none"> • Ne pas toucher les composants électriques sous tension. • Toujours porter des gants isolants secs. • S'isoler de la zone de travail et de la terre. • Déconnecter l'alimentation d'entrée avant de procéder à l'entretien de l'unité. • Le fil d'apport et les composants d'alimentation peuvent être porteurs de la tension de soudage. <p>Les FUMÉES ET GAZ peuvent être nocifs pour la santé.</p> <ul style="list-style-type: none"> • Garder la tête à l'écart des fumées. • Utiliser une ventilation suffisante, un échappement au niveau de l'arc électrique, voire les deux pour maintenir les fumées et les gaz à l'écart de la zone de respiration et de la zone générale. • En cas d'utilisation abusive, du liquide peut être éjecté de la batterie; éviter tout contact. <p>La FORMATION DE PROJECTIONS ET D'ÉTINCELLES peut provoquer un incendie ou une explosion.</p> <ul style="list-style-type: none"> • Ne pas utiliser à proximité d'un matériau inflammable. • Ne pas utiliser sur des contenants fermés. <p>Les RAYONS D'ARC ELECTRIQUE peuvent provoquer des blessures oculaires et des brûlures. Le BRUIT peut endommager l'ouïe.</p> <ul style="list-style-type: none"> • Porter une protection oculaire, auditive et corporelle adaptée.
 <p>A-TNH: 42 04091374 Spec. Date: 2023-05-31</p>	<p>42.0409.1374</p> <p>This label is a mandatory safety label for the product and must be clearly visible and legible at all times. It is not to be removed, destroyed, or covered. The label is provided for informational purposes only. The manufacturer is not responsible for any damage or injury caused by the use of the product. For more information, please contact the manufacturer's customer service department. © 2023 Miller Electric Mfg. Co. All rights reserved.</p>

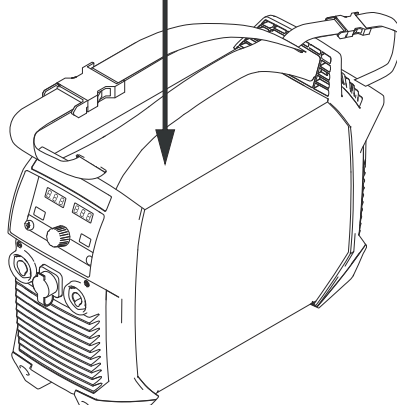

* MV welding systems: 1 ~ 120 - 230 V

Safety symbols on the rating plate:



Welding is dangerous. The following basic requirements must be met:

- Adequate welding qualifications
- Appropriate protective equipment
- Exclusion of unauthorized persons



Do not use the functions described here until you have fully read and understood the following documents:

- These Operating Instructions
- All system component Operating Instructions, especially the safety rules

Operating controls and connections

Control Panel

General

NOTE!

Because of software updates, certain functions may be available for your device but not described in these Operating Instructions or vice versa.

In addition, individual figures may also differ slightly from the operating elements of your device. These operating elements function in exactly the same way, however.

Safety

⚠ WARNING!

Danger from incorrect operation and work that is not carried out properly.

This can result in serious personal injury and damage to property.

- ▶ All the work and functions described in this document must only be carried out by technically trained and qualified personnel.
- ▶ Read and understand this document in full.
- ▶ Read and understand all safety rules and user documentation for this equipment and all system components.

Control panel

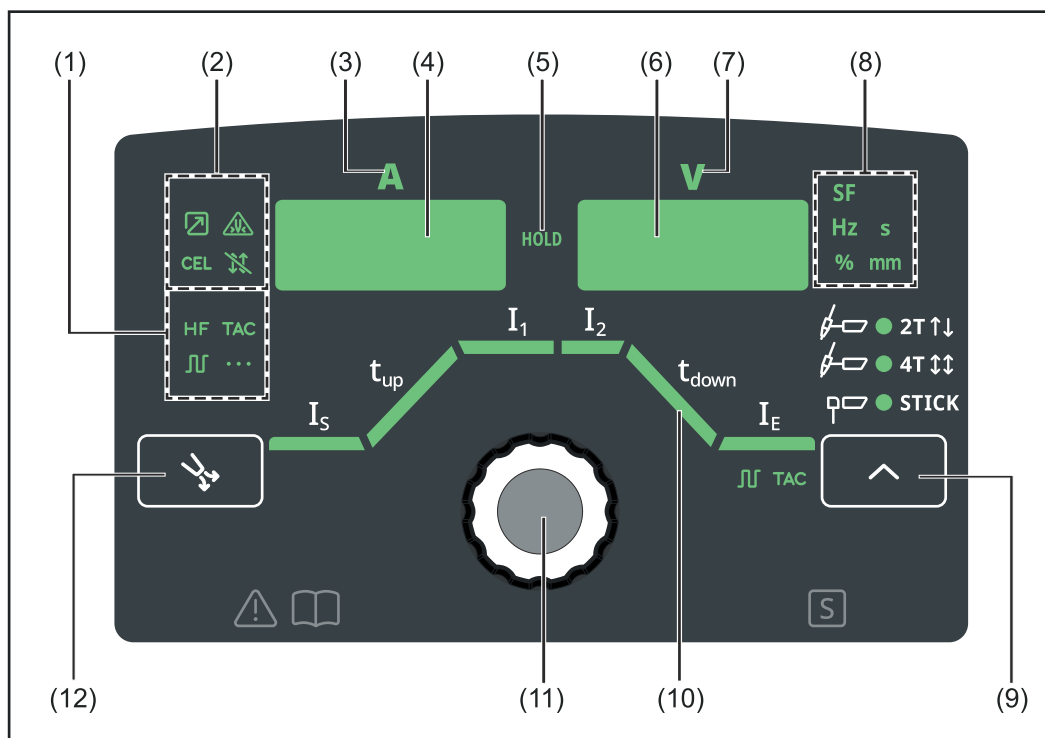

Item Name

- (1) Special indicators



HF ignition indicator (high frequency ignition)

Illuminates when the "IGn" setup parameter has been set to "on"



Tacking indicator

Illuminates when the "tAC" setup parameter has been set to a period of time



Pulsing indicator

Illuminates when the "F-P" setup parameter has been set to a pulse frequency



Spot welding indicator

Illuminates when the "SPt" setup parameter has been set to a spot welding time

(2) Special indicators



Remote control indicator

Illuminates when a foot-operated remote control is connected



Electrode overloaded indicator

Illuminates when the tungsten electrode is overloaded

Further information related to the "electrode overloaded" indicator can be found in the "TIG welding" section of the "Welding mode" chapter



CEL indicator

Illuminates when the "CEL" setup parameter has been set to "on"



Trigger indicator

Illuminates when the "tri" setup parameter has been set to "off"

(3) Welding current display

To display the welding current for the parameters:

- Starting current I_S
- Welding current I_1
- Lowering current I_2
- Final current I_E

Before the start of welding, the left digital display shows the set value. For I_S , I_2 , and I_E , the right digital display also indicates the % amount of the welding current I_1 .

After the start of welding, the left digital display shows the current actual value of the welding current.

The relevant parameters in the welding process are shown by the illuminated segment in the welding parameter overview (10)

(4) Left digital display

(5) HOLD indicator

At the end of welding, the current actual values for the welding current and welding voltage are saved - the "hold" indicator illuminates.

The "hold" indicator relates to the last main current I_1 to be reached. Any further interaction with the welding system will cause the "hold" indicator to go out.

IMPORTANT! No hold values are output if the main current phase has never been reached.

(6) Right digital display

(7) Welding voltage indicator

Illuminates when parameter " I_1 " is selected.

During welding, the current actual value of the welding voltage is shown on the right digital display.

Before welding, the right digital display shows:

- 0.0 for selected TIG welding operating modes
- Current value of the open circuit voltage if the setup parameter "tri" is set to "off" or if the manual metal arc welding mode is selected (after a delay of 3 seconds; 93 V is approximately the average value of the pulsed open circuit voltage)

(8) Unit indicators

S

s indicator

Illuminates if the parameters "tup" and "tdown" have been selected, as well as the following setup parameters:

GPr | GPo | SPt | tAC | t-S | t-E | Hti | Ito | ArC | St1 | St2 | SPb

Hz

Hz indicator

Illuminates:

When a value for the pulse frequency has been set for the "F-P" setup parameter

If the "F-P" setup parameter is selected.

%

% indicator

Illuminates when parameters " I_S ", " I_2 ", and " I_E " have been selected, as well as the setup parameters "dcY", "I-G", and "HCU"

mm

mm indicator

Illuminates when the "ELd" setup parameter is set

(9) "Mode" button

For selecting the operating mode



2-step mode



4-step mode



MMA welding

When an operating mode is selected, the corresponding LED lights up. If the "Trigger" parameter is set to "oFF" in the Setup menu or a foot-operated remote control is connected, the 2T and 4T LEDs light up at the same time.

(10) Welding parameter overview

The welding parameter overview contains the most important welding parameters for the welding operation. The welding parameter sequence is depicted by a "washing line" structure. Navigation within the welding parameter overview is carried out by turning the dial.

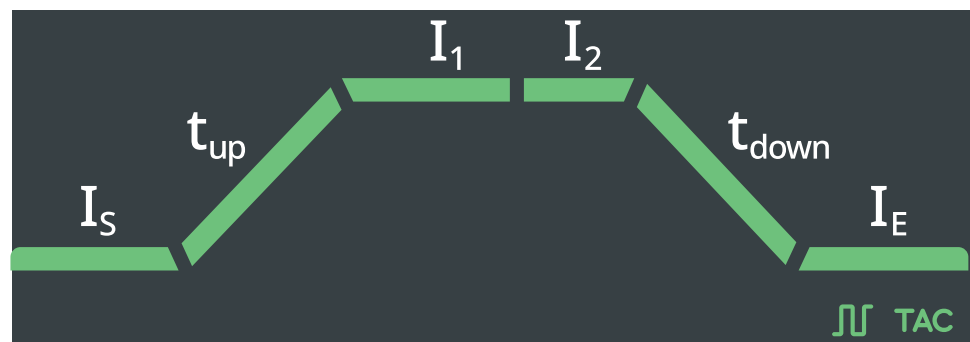

The welding parameter overview contains the following welding parameters:
Starting current I_S

For TIG welding

UpSlope t_{up}

Period of time it takes to rise from the starting current I_S to the specified main current I_1 during TIG welding

t_u for the UpSlope is displayed on the left digital display.

IMPORTANT! The UpSlope t_{up} is saved separately for the following operating modes:

- 2-step mode
- 4-step mode
- When the "Trigger" setup parameter is set to "oFF"
- When a foot-operated remote control has been connected

Main current (welding current) I_1

- For TIG welding
- For manual metal arc welding

Lowering current I_2

For TIG 4-step mode

DownSlope t_{down}

Period of time it takes to fall from the specified main current I_1 to the final current I_E during TIG welding

t_d for the DownSlope is displayed on the left digital display.

IMPORTANT! The DownSlope t_{down} is saved separately for the following operating modes:

- 2-step mode
- 4-step mode
- When the "Trigger" setup parameter is set to "oFF"

Final current I_E

For TIG welding



Pulses *)

Pulse frequency for TIG welding



Tacking *)

Duration of the pulsed welding current

*)

The pulsing and tacking parameters are only displayed if the setup parameter "Ptd - pulse TAC display" is set to "on".

(11) **Dial with rotary/push button function**

For selecting elements, setting values, and scrolling through lists

(12) **Gas-test button**

For setting the required shielding gas volume on the gas pressure regulator

When the gas-test button is pressed, shielding gas will flow for 30 s. Press the button again or start welding to stop the gas flow prematurely.

Connections, Switches, and Mechanical Components

Operating Controls, Connections, and Mechanical Components

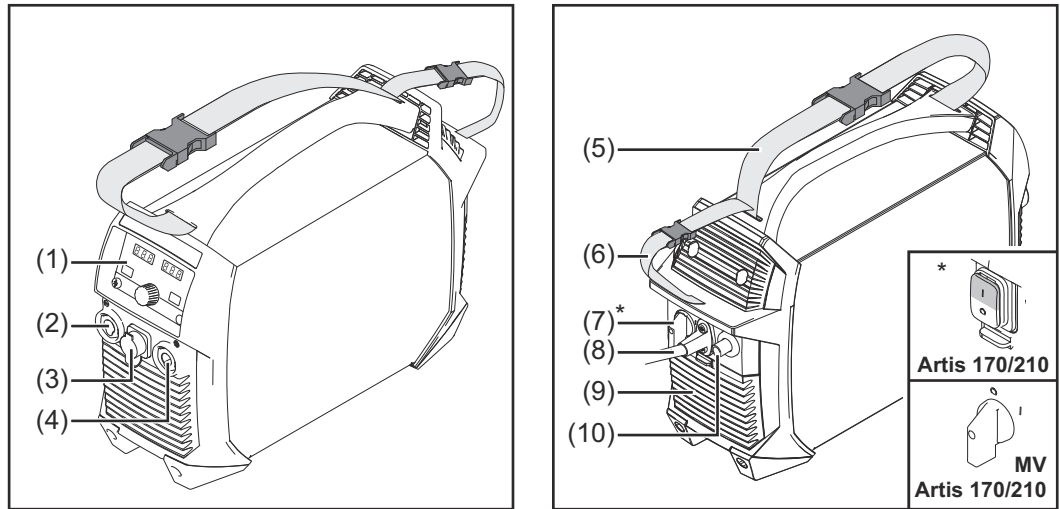

- | | |
|------|--|
| (1) | Control panel |
| (2) | <p>(-) Current socket with integrated gas connection
 For connecting:
 the TIG welding torch
 the electrode cable during manual metal arc welding</p> |
| (3) | <p>TMC connection (TIG Multi Connector)
 For connecting the control plug of the TIG welding torch
 For connecting foot remote controls
 For connecting remote controls for manual metal arc welding</p> |
| (4) | <p>(+) Current socket with bayonet latch
 Connect the grounding cable here</p> |
| (5) | Carry strap |
| (6) | <p>Cable strap
 To hold the mains cable and the welding power-leads
 IMPORTANT! Do not use the cable strap to transport the device!</p> |
| (7) | Mains switch |
| (8) | <p>Mains cable with strain relief
 For MV devices: mains cable to plug in
 (see "Connecting the Mains Cable" on page 38)</p> |
| (9) | Air filter |
| (10) | Shielding gas connection socket |

Installation and Startup

Minimum equipment for welding operations

General

Depending on the welding process, a minimum level of equipment is required to work with the welding system.

The following describes the welding processes and the corresponding minimum equipment for welding operations.

TIG DC welding

- Welding system
 - Return lead cable
 - TIG welding torch with or without rocker switch
 - Gas connection (shielding gas supply)
 - Filler metal depending on application
-

MMA welding

- Welding system
- Return lead cable
- Electrode holder
- Stick electrodes, depending on application

Before installation and initial operation

Safety

WARNING!

Danger from incorrect operation and work that is not carried out properly.

This can result in serious personal injury and damage to property.

- ▶ All the work and functions described in this document must only be carried out by technically trained and qualified personnel.
 - ▶ Read and understand this document in full.
 - ▶ Read and understand all safety rules and user documentation for this equipment and all system components.
-

Intended use

The welding system is intended exclusively for TIG welding and manual metal arc welding.

Any other use does not constitute proper use.

The manufacturer accepts no responsibility for any damage resulting from improper use.

Intended use also means

- Following all the instructions in these Operating Instructions
 - Carrying out all the specified inspection and maintenance work
-

Setup Regulations

The device has been tested according to degree of protection IP 23. This means:

- Protection against penetration by solid foreign bodies with diameters > 12.5 mm (0.49 in.)
- Protection against spraywater at any angle up to 60° from the vertical

The device can be set up and operated outdoors in accordance with degree of protection IP 23.

Direct moisture (e.g., from rain) must be avoided.

WARNING!

Danger from machines toppling over or falling.

This can result in serious personal injury and damage to property.

- ▶ Set up the device securely on an even, solid surface.
 - ▶ Check all screw connections are tightly fastened after installation.
-

The ventilation channel is a very important safety device. When selecting the setup location, ensure that the cooling air can enter or exit unhindered through the vents on the front and back. Any electrically conductive dust (e.g. from grinding work) must not be allowed to be sucked directly into the device.

Grid Connection

The devices are designed for the grid voltage stated on the rating plate. If the mains cable or mains plug has not been attached to your version of the appliance, these must be installed according to national standards. Fuse protection for the grid lead can be found in the technical data.



CAUTION!

Danger due inadequately dimensioned electrical installations.

This can lead to serious damage

- ▶ The grid lead and its fuse protection should be designed to suit the existing power supply.
The technical data on the rating plate should be followed.
-

Generator-powered operation

The welding system is generator-compatible.

The maximum apparent power $S_{1\max}$ of the welding system is required for dimensioning the necessary generator output.

The maximum apparent power $S_{1\max}$ of the welding system is calculated as follows:

$$S_{1\max} = I_{1\max} \times U_1$$

$I_{1\max}$ and U_1 according to the device rating plate and technical data

The generator apparent power S_{GEN} needed is calculated using the following rule of thumb:

$$S_{\text{GEN}} = S_{1\max} \times 1.35$$

A smaller generator can be used when not welding at full power.

IMPORTANT! The generator apparent power S_{GEN} must not be less than the maximum apparent power $S_{1\max}$ of the welding system!

When single-phase devices are being operated with a three-phase generator, note that the stated apparent power of the generator is often just the total that can be present across all three phases of the generator. If necessary, obtain further information about the single-phase power of the generator from the generator manufacturer.

NOTE!

The voltage delivered by the generator must never fall outside of the mains voltage tolerance range.

The mains voltage tolerance is specified in the "Technical data" section.

Connecting the Mains Cable

General

If a welding system is delivered without a mains cable installed, a mains cable corresponding to the welding system's connection voltage must be connected before commissioning.

The mains cable is included in the scope of supply for the welding system.

Safety

WARNING!

Danger from incorrect operation and work that is not carried out properly.

This can result in serious personal injury and damage to property.

- ▶ All the work and functions described in this document must only be carried out by technically trained and qualified personnel.
- ▶ Read and understand this document in full.
- ▶ Read and understand all safety rules and user documentation for this equipment and all system components.

Connecting the mains cable

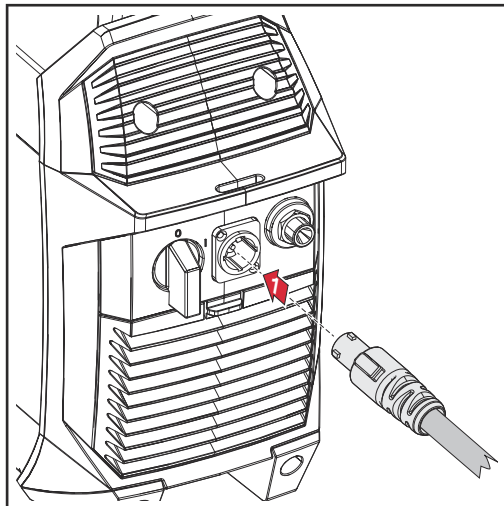

- 1** To connect the mains cable:
 - Plug in the mains cable
 - Turn the mains cable 45° to the right until it audibly locks into place

IMPORTANT! If the welding system is equipped with a mains cable but no mains plug, connection to the public grid must only be carried out in accordance with national guidelines and only by trained and qualified personnel.

Commissioning

Safety

WARNING!

Danger from electrical current.

This can result in serious personal injury and damage to property.

- ▶ Before starting work, switch off all devices and components involved, and disconnect them from the grid.
 - ▶ Secure all devices and components involved so they cannot be switched back on.
 - ▶ After opening the device, use a suitable measuring instrument to check that electrically charged components (such as capacitors) have been discharged.
-

WARNING!

Danger of electrical current due to electrically conductive dust in the device.

This can result in severe personal injury and damage to property.

- ▶ Only operate the device if an air filter is fitted. The air filter is a very important safety device for achieving IP 23 protection.
-

General

Commissioning of the welding system is described in relation to a standard configuration for the main usage scenario of TIG welding.

The standard configuration consists of the following system components:

- Welding system
 - TIG manual welding torch
 - Gas pressure regulator
 - Gas cylinder
-

Connecting the Gas Cylinder

WARNING!

Danger of falling gas cylinders.

This can result in serious personal injury and damage to property.

- ▶ Securely set up the gas cylinders on a level and stable surface. Secure gas cylinders to prevent them from falling over.
 - ▶ Please observe the gas cylinder manufacturer's safety rules.
-

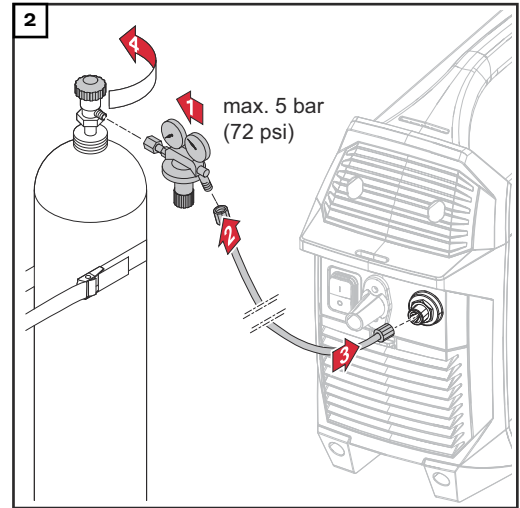
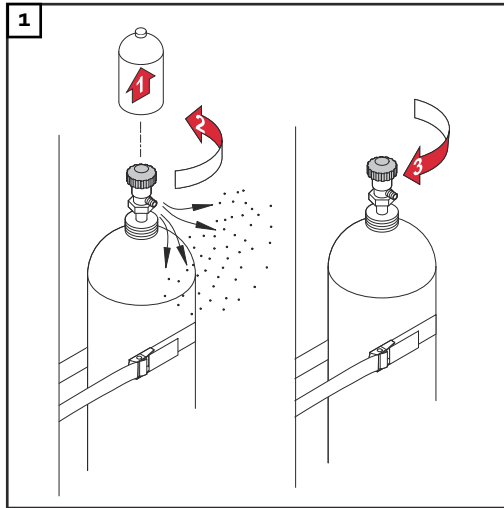

Connecting the welding torch to the welding system

NOTE!

Do not use pure tungsten electrodes for Artis welding systems (color code: green).

- 1** Fit parts to the welding torch according to the Operating Instructions for the welding torch

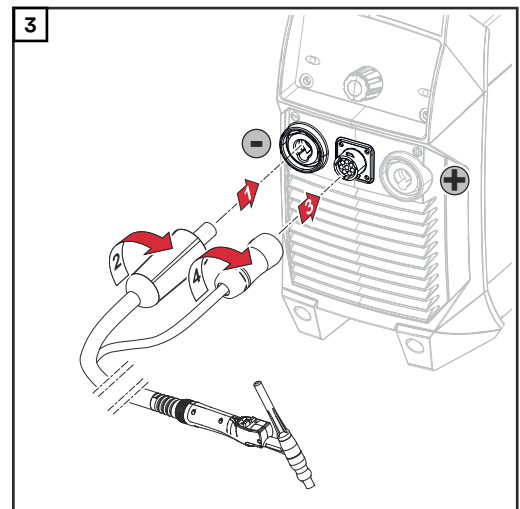
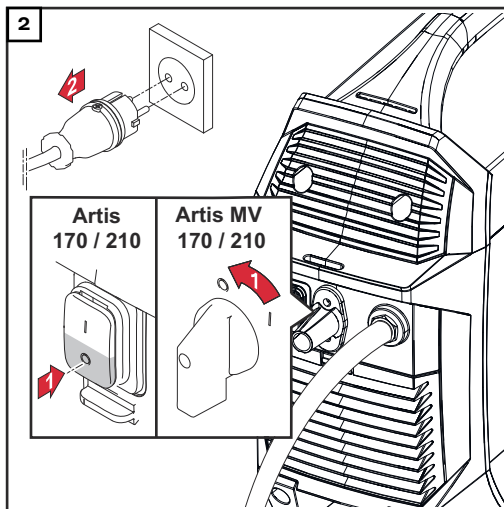

Establishing a Ground Earth Connection with the Workpiece

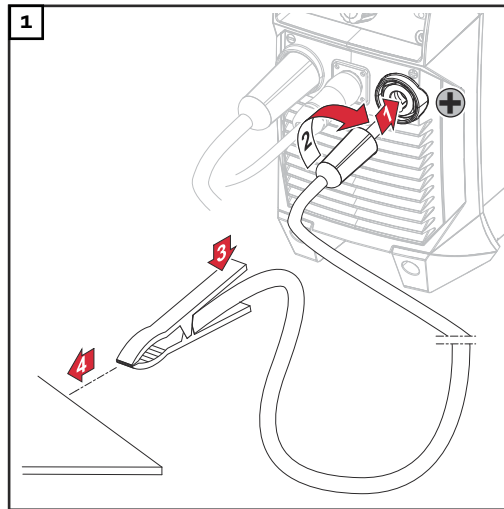

Measuring the welding circuit resistance "r"

IMPORTANT! For optimum welding results, determine the welding circuit resistance " r " before starting welding.

The welding circuit resistance " r " must also be determined if one of the following components of the welding system is changed:

- Torch hosepack
- Welding torch
- Grounding cable

For more information on determining the welding circuit resistance, refer to the 2nd TIG menu (see page [74](#)).

Welding Mode

TIG Operating Modes

Safety



WARNING!

Danger due to incorrect operation.

This can result in severe personal injury and damage to property.

- ▶ Do not use the functions described here until you have fully read and understood the Operating Instructions.
- ▶ Do not use the functions described here until you have fully read and understood all of the Operating Instructions of the system components, especially the safety rules.

Follow the guidelines referring to setting, setting range, and units of measurement for the available parameters in the "Setup Menu" section.

Symbols and explanations

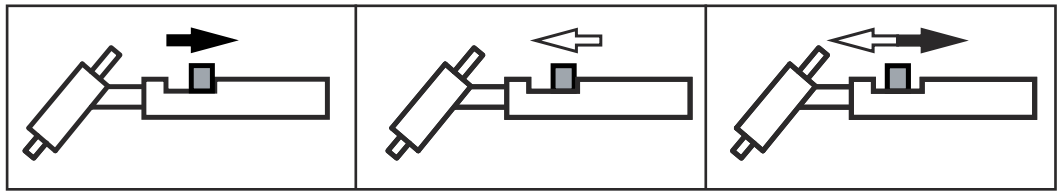

Pull back and hold the torch trigger | Release the torch trigger | Briefly pull back the torch trigger (< 0.5 s)

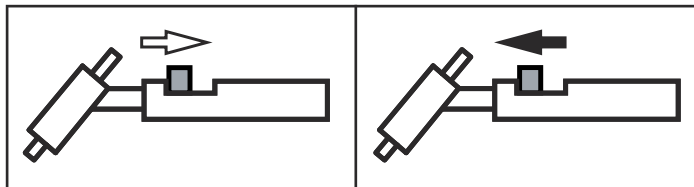

Push the torch trigger forward and hold | Release the torch trigger

I_S	Starting-current phase: the temperature is raised gently at low welding current, so that the filler metal can be positioned correctly
t_S	Starting current duration
t_{up}	UpSlope phase: steady rise of the starting current to the main current (welding current) I_1
I_1	Main current phase (welding current phase): uniform thermal input into the parent material, whose temperature is raised by the advancing heat
I_2	Lowering current phase: intermediate lowering of the welding current to avoid local overheating of the parent material
t_{down}	DownSlope phase: steady lowering of the welding current until it reaches the final current
I_E	Final current phase: to avoid local overheating of the parent material caused by heat accumulation at the end of welding. This prevents possible sagging of the weld seam.
t_E	Final current duration
Spt	Spot welding time
GPr	Gas pre-flow time
GPo	Gas post-flow time

2-Step Mode

- Welding: Pull back the torch trigger and hold it in this position
- End of welding: Release the torch trigger

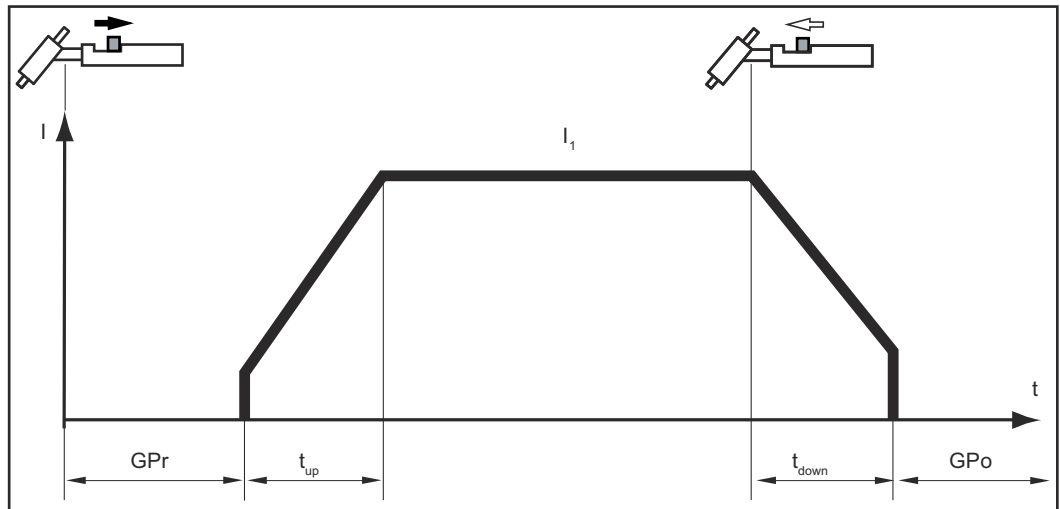

2-step mode

The Setup menu can be used to set a starting current time (t-S) and a final current time (t-E) for 2-step mode.

4-Step Mode

- Start of welding with starting current I_S : pull back the torch trigger and hold it in this position
- Welding with main current I_1 : release the torch trigger
- Lowering to final current I_E : pull back the torch trigger and hold it in this position
- End of welding: release the torch trigger

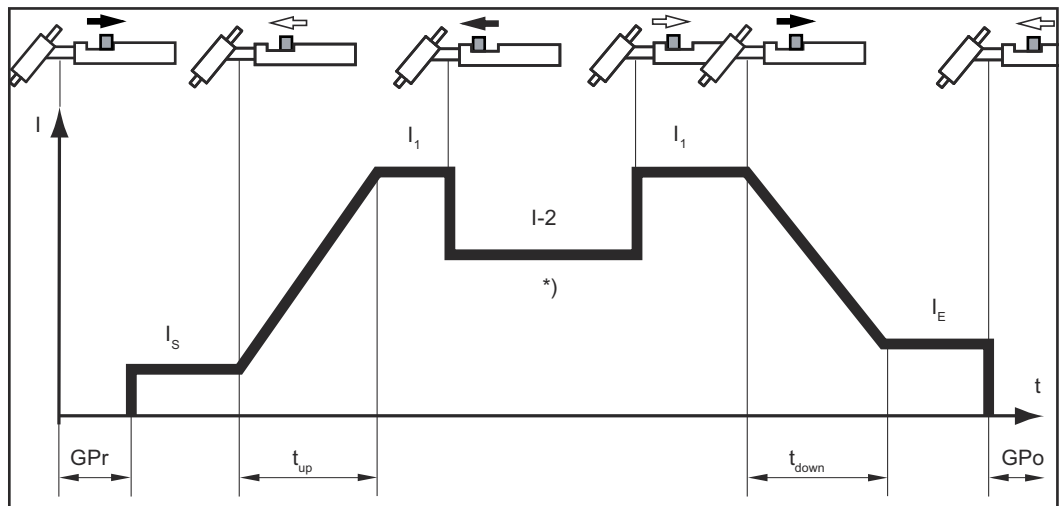

4-step mode

*) Intermediate lowering

With intermediate lowering, the welding current is lowered to the set lowering current $I-2$ during the main current phase.

- To activate intermediate lowering, push the torch trigger forward and hold it in this position
- Release the torch trigger to resume the main current

Spot Welding

If a value has been set for the setup parameter SPt, then 2-step mode operating mode is the same as spot welding operating mode. The spot welding special display illuminates on the control panel.

- Welding: Briefly pull back the torch trigger
The duration of welding corresponds to the value that was entered for the setup parameter SPt.
- Premature ending of the welding process: Pull back the torch trigger again

When using a foot remote control, the spot welding time begins when the foot remote control is pressed. Foot remote controls cannot be used to adjust the power.

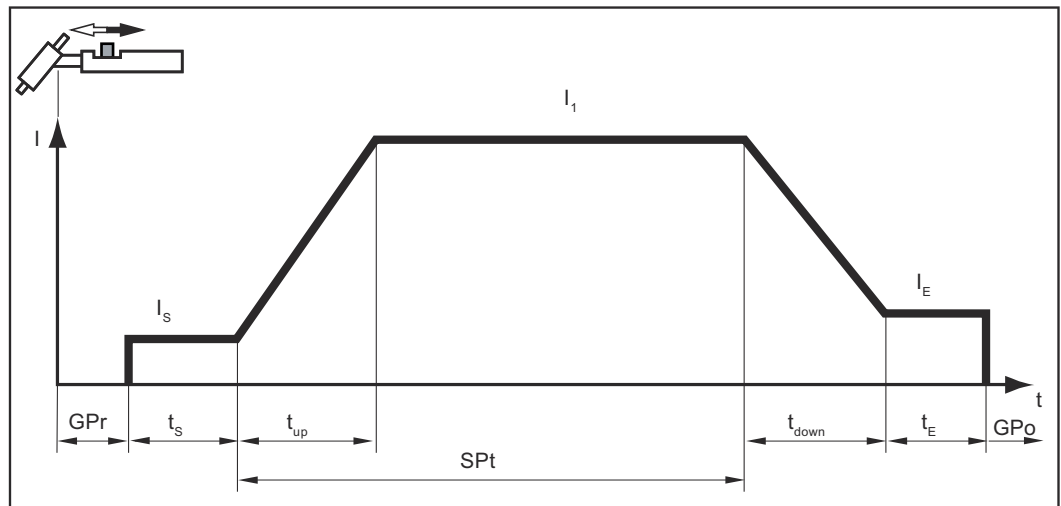

TIG welding

Safety

WARNING!

Danger from incorrect operation and work that is not carried out properly.

This can result in serious personal injury and damage to property.

- ▶ All the work and functions described in this document must only be carried out by technically trained and qualified personnel.
- ▶ Read and understand this document in full.
- ▶ Read and understand all safety rules and user documentation for this equipment and all system components.

WARNING!

Danger from electrical current.

This can result in serious personal injury and damage to property.

- ▶ Before starting work, switch off all the devices and components involved and disconnect them from the grid.
- ▶ Secure all devices and components involved so they cannot be switched back on.
- ▶ After opening the device, use a suitable measuring instrument to check that electrically charged components (such as capacitors) have been discharged.

Preparation

WARNING!

Danger from electrical current.

This can result in serious personal injury and damage to property.

- ▶ When the power switch is switched to position - I -, the tungsten electrode of the welding torch is live.
- ▶ Ensure that the tungsten electrode is not touching any people or electrically conductive or grounded parts (housing, etc.).

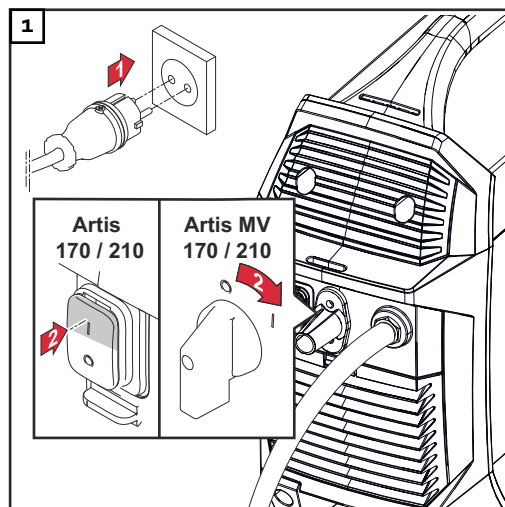

TIG welding



- 1 Select the desired TIG operating mode by pressing the operating mode button:



- 2 Press the dial



In the welding parameter overview, the assigned welding parameters illuminate to around 50%. The segment of the currently selected welding parameter illuminates fully.

- 3 Turn the dial and select the welding parameter to be set (so that the segment assigned to the welding parameter in the welding parameter overview illuminates)



- 4 Press the dial



- 5 Turn the dial and adjust the value of the selected welding parameter



- 6 Press the dial to confirm the value of the welding parameter



- 7 Adjust other parameters in the Setup menu if necessary (Details in the "Setup settings" chapter from page [71](#))

- 8 Open the gas cylinder valve

9 Adjust quantity of shielding gas:

Press the gas-test button



The gas pre-flow test lasts for 30 seconds at the most. Press the button again to stop the gas flow prematurely.

Turn the adjusting screw on the bottom of the gas pressure regulator until the manometer displays the desired quantity of gas

NOTE!

All parameter set values that are set using the dial are saved until their next alteration.

This applies even if the welding system is switched off and on again.

10 Commence the welding process (ignite arc)

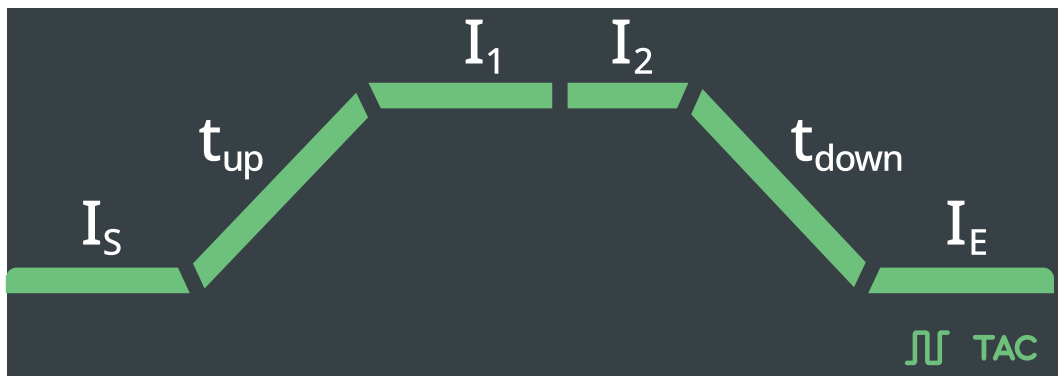

Welding parameters



I_S **Starting current**
1 - 200% of the main current I_1
Factory setting 35%

t_{up} **UpSlope**
off / 0.01 - 9.9 s
Factory setting: 0.5 s
IMPORTANT! The UpSlope t_{up} is saved separately for the following operating modes:
- 2-step mode
- 4-step mode
- When the "Trigger" setup parameter is set to "oFF"
- When a foot-operated remote control has been connected

I_1 **Main current**
10 – 170 A ... Artis 170
10 – 210 A ... Artis 210
Factory setting: 100 A

I_2	Lowering current (only in 4-step mode) 1 - 200% (of the main current I_1) Factory setting: 50%
t_{down}	DownSlope off / 0.01 - 9.9 s Factory setting: 1.0 s IMPORTANT! The DownSlope t_{down} is saved separately for the following operating modes: - 2-step mode - 4-step mode - When the "Trigger" setup parameter is set to "oFF"
I_E	Final current 1 - 100% (of the main current I_1) Factory setting: 30%
	 Pulses * F-P (pulse frequency) off / 0.2 - 990 Hz Factory setting: off
	 Tacking * Duration of the pulsed welding current off / 0.1 - 9.9 s / on Factory setting: off
*	The pulsing and tacking parameters are only displayed if the setup parameter "Ptd - pulse TAC display" is set to "on".

Igniting the arc

Igniting the arc using high frequency (HF ignition)

CAUTION!

Risk of injury due to an electric shock

Although Fronius devices comply with all the relevant standards, high frequency ignition can transmit a harmless but noticeable electric shock under certain circumstances.

- ▶ Use prescribed protective clothing, especially gloves!
- ▶ Only use suitable, completely intact, and undamaged TIG hosepacks!
- ▶ Do not work in damp or wet environments!
- ▶ Take special care when working on scaffolding, work platforms, in tight, difficult to access or exposed places, or when welding out-of-position!

HF ignition is activated when the setup parameter "IGn" is set to "on". The HF ignition special indicator illuminates on the control panel.



Unlike contact ignition, there is no risk of contaminating the tungsten electrode and workpiece during HF ignition.

Procedure for HF ignition:

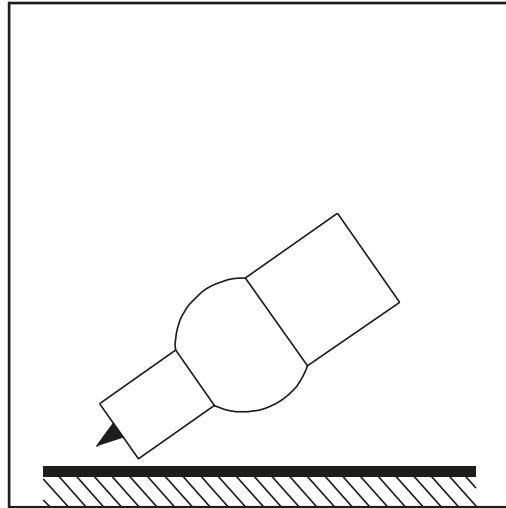

- 1** Position the gas nozzle at the ignition point so that there is a gap of approximately 2 to 3 mm (5/64 - 1/8 in.) between the tungsten electrode and the workpiece. A gap exists.

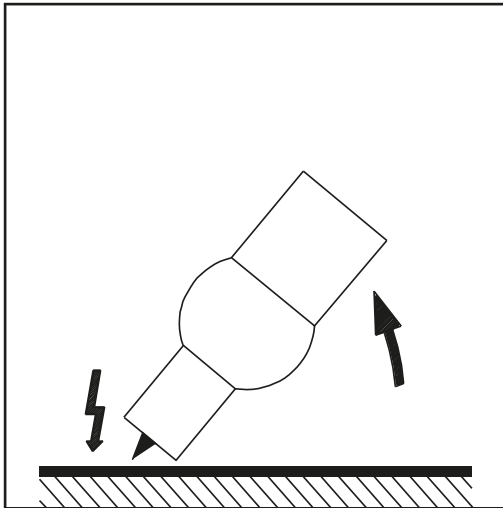

- 2 Increase the tilt angle of the welding torch and press the torch trigger according to the selected operating mode

The arc ignites without coming into contact with the workpiece.

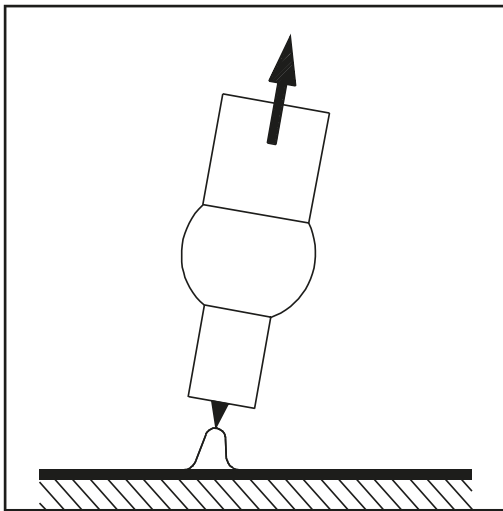

- 3 Tilt the welding torch to the normal position
- 4 Carry out welding

Contact ignition for welding torch with torch trigger

When the setup parameter IGn is set to OFF, the HF ignition is deactivated. The arc ignites when the workpiece makes contact with the tungsten electrode.

Procedure for igniting the arc using contact ignition for welding torches with torch trigger:

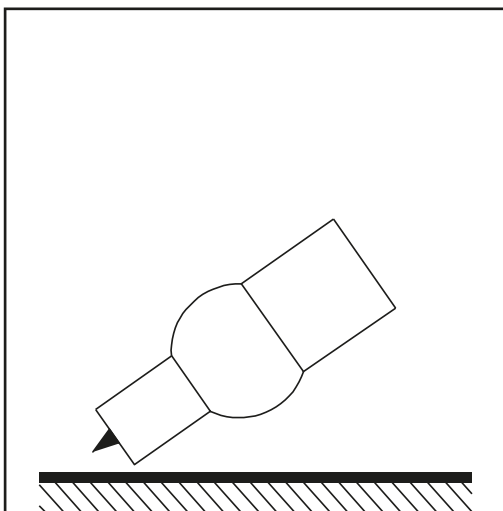

- 1 Position the gas nozzle at the ignition point so that there is a gap of approximately 2 to 3 mm (5/64 to 1/8 in.) between the tungsten electrode and the workpiece. A gap exists

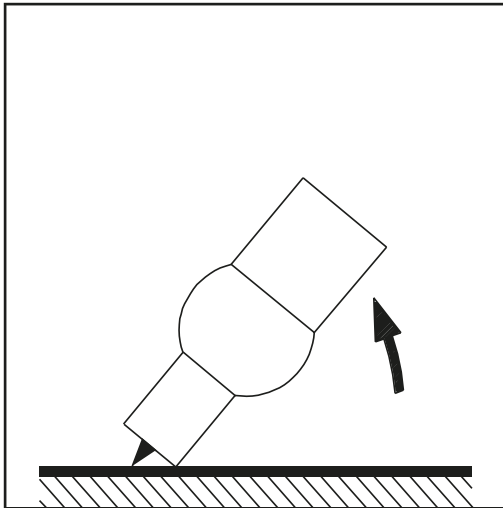

2 Press the torch trigger

Shielding gas flows

3 Gradually tilt the welding torch up until the tungsten electrode touches the workpiece

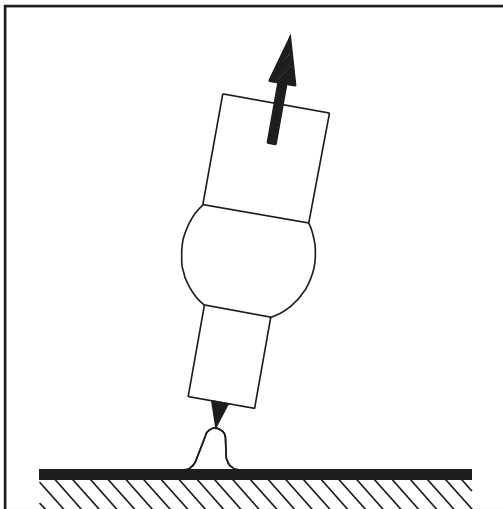

4 Raise the welding torch and rotate it into its normal position

The arc ignites.

5 Carry out welding

Contact ignition for welding torch without torch trigger

When the setup parameter "IGn" is set to "oFF", the HF ignition is deactivated. The arc ignites when the workpiece makes contact with the tungsten electrode.

The setup parameter "Tri" must be set to "oFF".

Procedure for igniting the arc using contact ignition for welding torches without torch trigger:

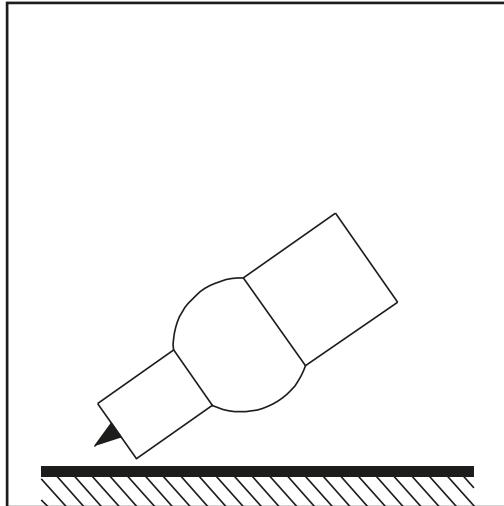

- 1 Position the gas nozzle at the ignition point so that there is a gap of approximately 2 to 3 mm (5/64 to 1/8 in.) between the tungsten electrode and the workpiece. A gap exists

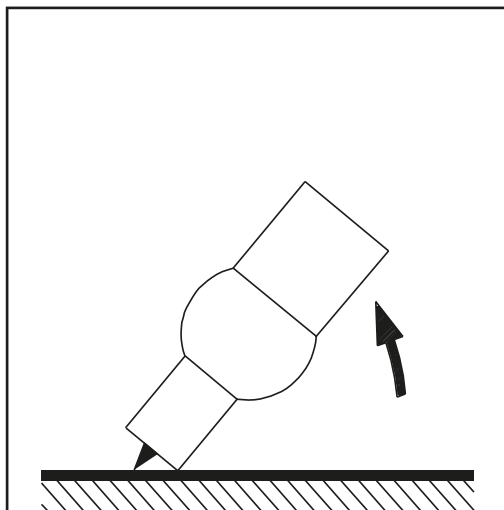

- 2 Actuate gas cut-off valve
Shielding gas flows

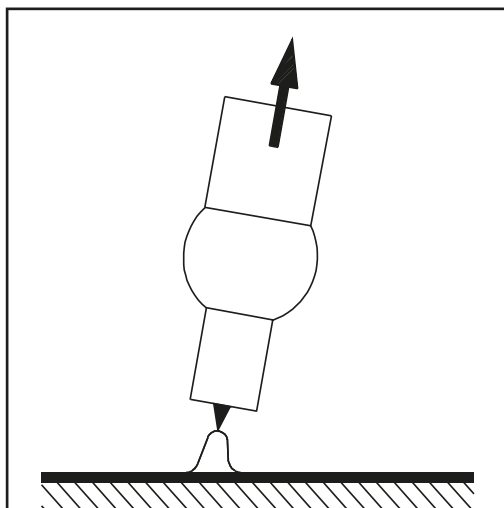

- 3 Gradually tilt the welding torch up until the tungsten electrode touches the workpiece

- 4 Raise the welding torch and rotate it into its normal position

The arc ignites.

- 5 Carry out welding

Igniting the arc using high-frequency contact (Touch-HF)

 **CAUTION!**

Risk of injury due to an electric shock

Although Fronius devices comply with all relevant standards, the high-frequency ignition can transmit a harmless but noticeable electric shock under certain circumstances.

- ▶ Use prescribed protective clothing, especially gloves!
 - ▶ Only use suitable, completely intact and undamaged TIG hosepacks!
 - ▶ Do not work in damp or wet environments!
 - ▶ Take special care when working on scaffolds, work platforms, in forced positions, in tight, difficult to access or exposed places!
-

The welding process is initiated by briefly touching the workpiece with the tungsten electrode. The high-frequency ignition is performed after the set HF ignition delay time has elapsed.

Overloading of the tungsten electrode

If the tungsten electrode is overloaded, the "electrode overloaded" indicator illuminates on the control panel.



Possible causes of an overloaded tungsten electrode:

- Diameter of the tungsten electrode is too small
- Main current I_1 value is set too high

Remedy:

- Use tungsten electrode with larger diameter (in this case, the "ELd" setup parameter value must also be adjusted to the new electrode diameter)
- Reduce the main current

IMPORTANT! The "electrode overloaded" display is tailored for use with ceriated tungsten electrodes. For all other electrodes, the "electrode overloaded" indicator can be used as a guide.

End of Welding

- 1** Depending on the set operating mode, end welding by releasing the torch trigger
- 2** Wait for the set gas post-flow and hold the welding torch in position over the end of the weld seam.

It is also possible to end welding with the TIG Comfort Stop (CSS) function on welding torches with or without a torch trigger. This function can be adjusted in the TIG - 2nd level Setup menu (see page [74](#)).

Special functions

Arc break monitoring function

If the arc breaks and no current flow takes place during the time set in the Setup menu, the welding system automatically switches off. The control panel displays the service code "no | Arc".

Press any button on the control panel or the torch trigger to restart the welding process.

The "2nd level Setup menu" section describes how to set the arc break monitoring (Arc) setup parameters.

Ignition Time-Out

The welding system has an Ignition Time-Out.

If the torch trigger is pressed, gas pre-flow begins immediately and the ignition procedure is then initiated. If no arc emerges during the period of time set in the Setup menu, the welding system automatically switches off. The control panel displays the service code "no | IGn".

Press any button on the control panel or the torch trigger to launch a further attempt.

The "2nd level Setup menu" section describes how to set the "Ignition Time-Out" (Ito) parameter.

TIG pulsing

The welding current set at the start of welding may not always be optimum for the entire welding process:

- If the amperage is too low, the parent material will not be sufficiently melted
- If overheating occurs, there is a danger that the liquid weld pool may drip

The TIG pulsing function is able to help with this (TIG welding with a pulsing welding current):

A low base current I-G rises steeply to a significantly higher pulse current I1 and falls again, after the set time dcY (duty cycle), to the base current I-G.

During TIG pulsing, small sections of the welding point are quickly melted and then allowed to quickly solidify again.

During manual applications, the welding wire is applied in the maximum current phase during TIG pulsing (only possible in the low frequency range from 0.25 - 5 Hz). Higher pulse frequencies are mostly used in automated applications and mainly serve to stabilize the arc.

TIG pulsing is used to weld steel pipes when welding out-of-position or to weld thin sheet metal.

TIG pulsing in operation:

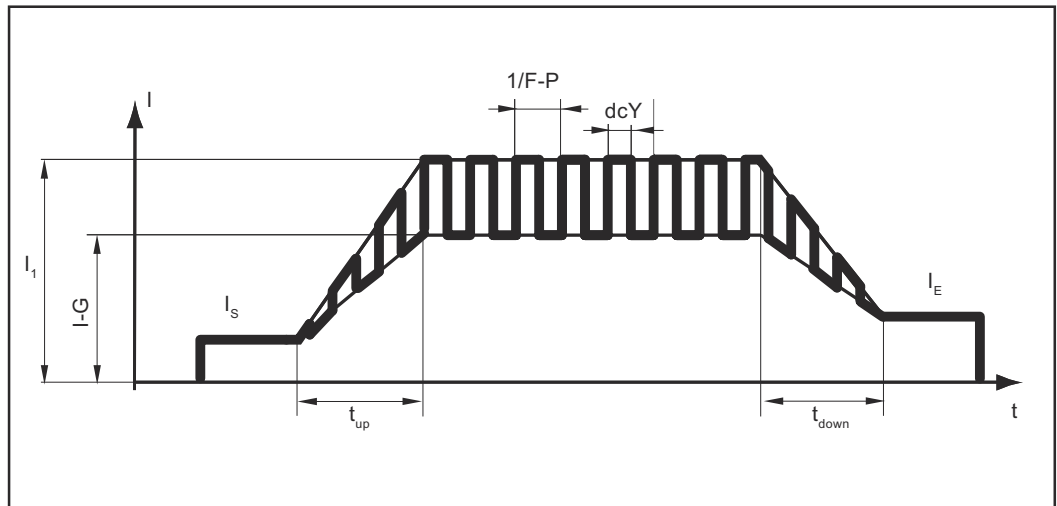

TIG pulsing - welding current progression curve

Key:

I_S	Starting current	$F-P$	Pulse frequency *)
I_E	Final current	dcY	Duty cycle
t_{up}	UpSlope	$I-G$	Base current
t_{Down}	DownSlope	I_1	Main current

*) ($1/F-P =$ Time between two impulses)

Tacking function There is a tacking function on the welding system.

When a period of time is set for the setup parameter t_{AC} (tacking), the tacking function is assigned to the 2-step and 4-step modes. The process of the operating modes remains unchanged. During this time, a pulsed welding current is available, which optimizes the merging of the weld pool when tacking two components.

Tacking function in operation:

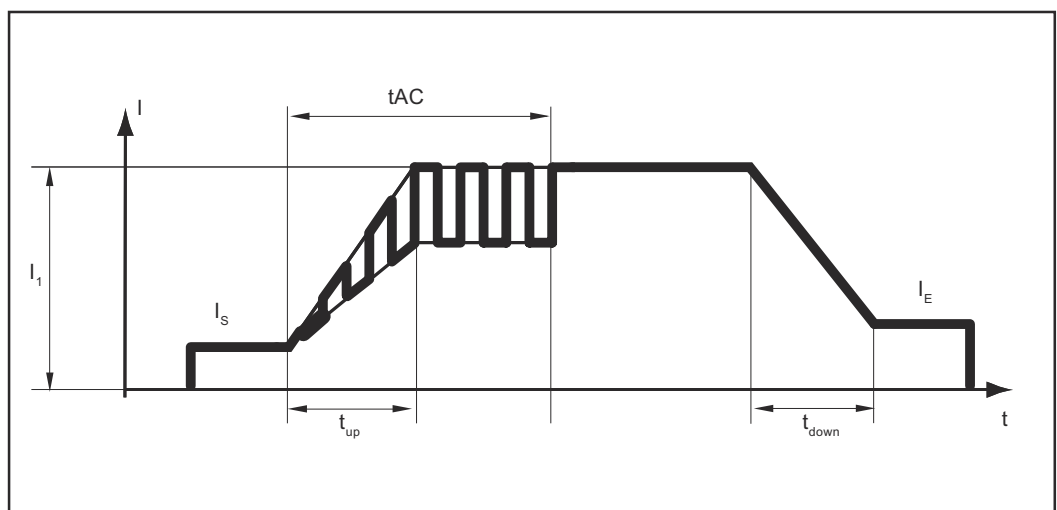

Tacking function - welding current curve

Key:

tAC	Duration of pulsed welding current for tacking process
I _S	Starting current
I _E	Final current
t _{up}	UpSlope
t _{Down}	DownSlope
I ₁	Main current

IMPORTANT! When using a pulsed welding current:

- The welding system automatically regulates the pulse parameters in relation to the set main current I₁.
- No pulse parameters have to be set.

The pulsed welding current starts

- After the starting-current phase I_S has finished
- With the UpSlope phase t_{up}

Depending on the set tAC time, the pulsed welding current can be stopped up to and including the final-current phase I_E (tAC setup parameter to "On").

After the tAC time has passed, further welding is carried out at a constant welding current. Set pulse parameters are available if applicable.

IMPORTANT! To set a defined tacking time, the setup parameter tAC can be combined with the setup parameter SPt (spot welding time).

Manual Metal Arc Welding

Safety

WARNING!

Danger from incorrect operation and work that is not carried out properly.

This can result in serious personal injury and damage to property.

- ▶ All the work and functions described in this document must only be carried out by technically trained and qualified personnel.
 - ▶ Read and understand this document in full.
 - ▶ Read and understand all safety rules and user documentation for this equipment and all system components.
-

WARNING!

Danger from electrical current.

This can result in serious personal injury and damage to property.

- ▶ Before starting work, switch off all the devices and components involved and disconnect them from the grid.
 - ▶ Secure all devices and components involved so they cannot be switched back on.
 - ▶ After opening the device, use a suitable measuring instrument to check that electrically charged components (such as capacitors) have been discharged.
-

Preparation

- 1 Set the power switch to - O -
- 2 Unplug mains plug
- 3 Remove TIG welding torch
- 4 Insert grounding cable and lock:
 - For manual metal arc DC- welding in the (+) current socket
 - For manual metal arc DC+ welding in the (-) current socket
- 5 Connect the other end of the grounding cable to the workpiece
- 6 Insert electrode cable and lock by turning to the right:
 - For manual metal arc DC- welding in the (-) current socket
 - For manual metal arc DC+ welding in the (+) current socket
- 7 Insert mains plug

WARNING!

Danger from electrical current.

This can result in serious personal injury and damage to property.

- ▶ When the power switch is switched to position - I -, the rod electrode in the electrode holder is live.
 - ▶ Ensure that the rod electrode is not touching any people or electrically conductive or grounded parts (housing, etc.).
-

- 8 Set the power switch to - I -

All displays on the control panel briefly illuminate.

MMA welding



- 1 Select the manual metal arc welding operating mode by pressing the operating mode button:



IMPORTANT! If the manual metal arc welding operating mode is selected, the welding voltage is only available after a delay of 3 seconds.

- 2 Turn the dial to set the welding current



The set value is immediately applied.

- 3 Adjust other parameters in the Setup menu if necessary (Details in the "Setup settings" chapter from page [81](#))

NOTE!

All parameter set values that are set using the dial are saved until their next alteration.

This applies even if the welding system is switched off and on again.

- 4 Initiate welding process

Manual Metal Arc Welding with Cel Electrodes

IMPORTANT! To weld with Cel electrodes, the setup parameter CEL must be set to "on" (also see page [81](#))!

Pulse welding

Pulse welding is welding with a pulsing welding current. It is used to weld steel pipes out-of-position or to weld thin sheet metal.

In these applications, the welding current set at the start of welding is not always optimum for the entire welding process:

- If the amperage is too low, the base material will not be sufficiently melted
- If overheating occurs, there is a danger that the liquid weld pool may drip

Adjustment range: off, 0.2 - 990 Hz

Operating principle:

- A low base current I-G rises steeply to the significantly higher pulse current I-P and drops back to the base current I-G after the Duty cycle dcY time.
- During pulse welding, small sections of the welding location melt quickly and then rapidly re-solidify.

NOTE!

The welding system regulates the duty cycle parameter "dcY" and the base current "I-G" according to the set pulse frequency.

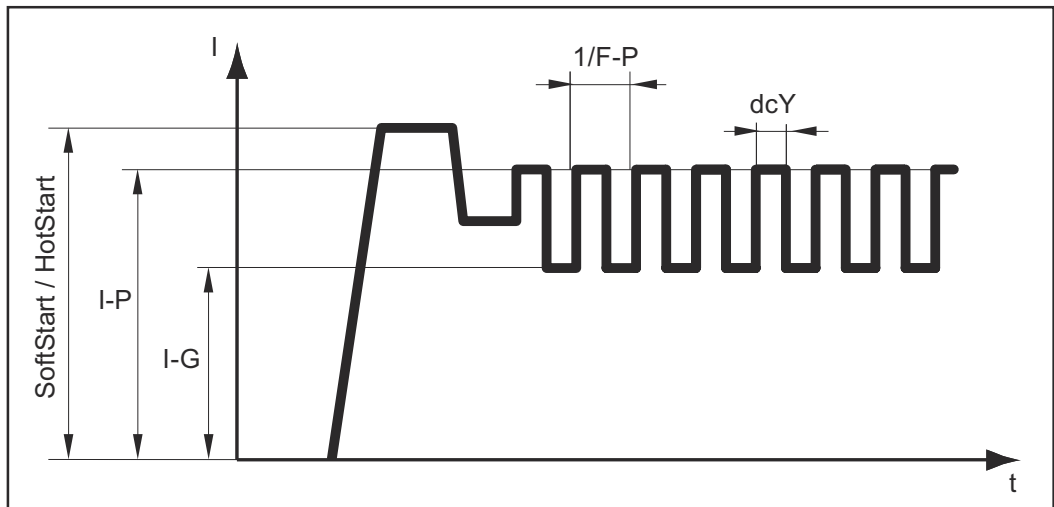

Pulse welding - welding current curve

Adjustable parameters:

- F-P Pulse frequency ($1/F-P =$ Time between two pulses)
- SoftStart / HotStart

Fixed parameters:

- I-G Base current
- dcY Duty cycle

Using pulse welding:

- 1 Select manual metal arc welding operating mode
- 2 Set the parameter "F-P" in the Setup menu to a value between 0.2 and 990 Hz

The pulsing special indicator illuminates on the control panel of the welding system.



Starting current > 100% (Hot-Start)

Advantages

- Improved ignition properties, even when using electrodes with poor ignition properties
- Better fusion of base material in the start phase, therefore less neutralization
- Slag inclusions largely avoided

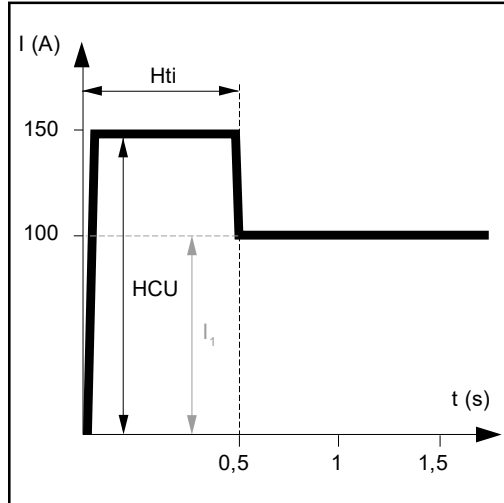

Key:

H_{ti}
Hot current time,
0-2 s,
Factory setting 0.5 s

H_{CU}
HotStart current,
0-200%,
Factory setting 150%

I₁
Main current = set welding current

Example of a starting current > 100% (HotStart)

Operation

During the set hot current time (H_{ti}) the welding current I_1 rises to the HotStart current H_{CU} .

The setting of the available parameters is described in the "Setup menu" section from page 81.

Starting current < 100% (SoftStart)

A starting current of < 100% (SoftStart) is suitable for basic electrodes. Ignition is carried out with a low welding current. As soon as the arc is stable, the welding current continues to increase until it reaches the welding current command value that was set.

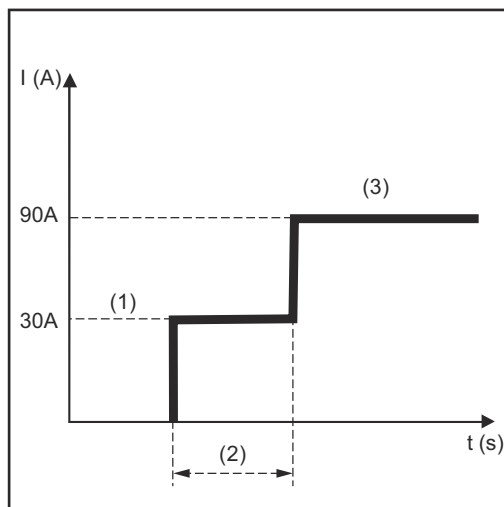

Advantages:

- Improvement of ignition properties with electrodes that ignite at a low welding current
- Slag inclusions largely avoided
- Reduction of welding spatter

- (1) HCU starting current
- (2) H_{ti} starting current time
- (3) Main current I_1

The starting current and starting current time are set in the Setup menu from page 81.

Example of a starting current < 100% (Soft-Start)

Anti-stick function

As the arc becomes shorter, the welding voltage may also fall so that the stick electrode is more likely to stick to the workpiece. This may also cause the stick electrode to burn out.

Electrode burn-out is prevented by activating the anti-stick function. If the stick electrode begins to stick, the welding system immediately switches the welding current off. The welding process can be resumed without problems once the stick electrode has been detached from the workpiece.

The anti-stick function can be activated or deactivated in the Setup menu, see page [81](#).

Setup Settings

The Setup Menu

General

The welding system Setup menu provides easy access to expert knowledge and additional functions. The Setup menu makes it possible to easily adjust the parameters for various tasks.

Located in the Setup menu are:

- Setup parameters with a direct effect on the welding process
 - Setup parameters for pre-setting the welding system
-

Accessing the Setup Menu



- 1** Press and hold the operating mode button
- 2** Press the gas-test button

The corresponding Setup menu will be displayed for the set operating mode.

- 3** To exit the Setup menu, press the operating mode button

Adjusting Parameters

The parameters in the Setup menu are adjusted as follows:

- 1 Turn the selection dial and select the desired setup parameter



- 2 Press selection dial to adjust the value for the setup parameter



The parameter is displayed on the left digital display. The currently set value for the parameter is displayed on the right digital display.

- 3 Turn selection dial and adjust the value of the setup parameter



- 4 Press selection dial to confirm the value of the setup parameter



Overview

The following sections describe the Setup menu:

- TIG Setup menu
- Rod electrode Setup menu

TIG Setup Menu

Parameters in the TIG Setup menu

The following parameters are available through the TIG Setup menu:

The image shows the parameter 'ELD' displayed in a yellow digital font on a green background.

Electrode diameter

0.0 - 3.2 mm

Factory setting: 2.4 mm

The image shows the parameter 'SPt' displayed in a yellow digital font on a green background.

Spot welding time/stitch welding time

off / 0.05 - 25 s

Factory setting: off

If a value has been set for the setup parameter SPt, this means that 2-step mode corresponds to the spot welding mode.

The spot welding special indicator illuminates on the control panel if a value for the spot welding time has been entered.

The image shows the parameter 'HF TAC' displayed in a yellow digital font on a black background, with a pulse waveform icon and three dots below it.The image shows the parameter 'SPb' displayed in a yellow digital font on a green background.

Interval pause time

This parameter is only available in 2-step mode and when the "SPt" parameter is activated.

off / 0.5 - 25 s

Factory setting: off

The image shows the parameter 'TAC' displayed in a yellow digital font on a green background.

Tacking

Tacking function - duration of the pulsed welding current at the start of the tacking process

off / 0.1 - 9.9 s / on

Factory setting: off

on

The pulsed welding current remains present until the end of the tacking process

0.1 - 9.9 s

The selected time begins with the UpSlope phase. After the set time has passed, further welding is carried out at a constant welding current. Set pulse parameters are available if applicable.

off
Tacking function is switched off

The tacking special indicator illuminates on the control panel if a value has been set.



Pulse frequency

off / 0.2 - 990 Hz
Factory setting: off

The set pulse frequency is also applied for the lowering current.

The pulsing special indicator illuminates on the control panel if a value for the pulse frequency has been entered.



Duty cycle

Relationship between pulse duration and base current duration at the set pulse frequency

10 - 90%
Factory setting: 50%



Base current

0 - 100% (of the main current I_1)
Factory setting: 50%



Starting current time

The starting current time indicates the duration of the starting-current phase.

off / 0.01 - 9.9 s
Factory setting: off

IMPORTANT! The starting current time is only valid for 2-step mode, spot welding, and operation using a foot-operated remote control.

In 4-step mode, the duration of the starting-current phase is determined by the torch trigger.



Final current time

The final current time indicates the duration of the final-current phase.

off / 0.01 - 9.9 s

Factory setting: off

IMPORTANT! The final current time is only valid for 2-step mode and spot welding. In 4-step mode, the duration of the final-current phase is determined by the torch trigger (section "TIG operating modes").



Gas pre-flow time

Duration of the gas pre-flow

0 - 9.9 s

Factory setting: 0.4 s



Gas post-flow time

Duration of the gas post-flow

0.2 - 25 s / Aut

Factory setting: Aut



Gas purging

off / 0.1 - 9.9 minutes

Factory setting: off

Shielding gas pre-purging starts once a value has been set for GPU.

For safety reasons, it is necessary to re-enter a value for GPU in order to re-start shielding gas pre-purging.

IMPORTANT! Shielding gas pre-purging is mainly required if condensate has built up after longer periods of downtime in the cold. Long hosepacks in particular may be affected by this.



Reset welding system

No / YES / ALL

Factory setting: No

YES:

Only the currently active welding mode is reset (2T / 4T / trigger = oFF / STICK / STICK CEL / foot-operated remote control)

ALL:
All operating modes are reset.



Left display Right display

TIG - 2nd level Setup menu

For setting the following parameters:

- r (welding circuit resistance)
 - Slope Time 1 (only in 4-step mode)
 - Slope Time 2 (only in 4-step mode)
 - Trigger
 - HF ignition
 - Pulse TAC display
 - Ignition Time-Out
 - Arc break monitoring
 - TIG Comfort Stop - Comfort Stop sensitivity
 - Break voltage
 - Main current changeover
-



2nd level Setup menu

For viewing "system active time", "system on time", "fuse" and "software version" parameters

For setting the "time shut down" parameter

Parameters in the TIG - 2nd level Setup menu

The following parameters are available through the second level of the TIG Setup menu:



Welding circuit resistance

For displaying the total resistance of the torch hosepack, welding torch, workpiece, and return lead cable

IMPORTANT! The ground earth connection and contact of the tungsten electrode must be made on a cleaned workpiece surface.

- 1 Establishing a ground earth connection
- 2 Select "r" and press the dial

The last measured value is displayed on the right display.

- 3 Place the tungsten electrode flush against the workpiece surface
- 4 Press the torch trigger or gas-test button

The value for "r" is determined, the right display shows "run".
The current value for "r" is then displayed in MOhm on the right display.

If an error occurs while determining the welding circuit resistance, "r" is displayed on the left display and "Err" is displayed on the right display.

Pressing the torch trigger or the gas-test button restarts the determination of the welding circuit resistance.

In the event of an error:

- Inspect torch hosepack, welding torch, and return lead cable for damage
 - Check connections and contacts
 - Check the cleanliness of the workpiece surface
-

5t1

Slope Time 1 (only available in 4-step mode)

Ramping time from the main current I_1 to the lowering current I_2

off / 0.01 - 9.9 s

Factory setting: 0.5 s

5t2

Slope Time 2 (only available in 4-step mode)

Ramping time from the lowering current I_2 back up to the main current I_1

off / 0.01 - 9.9 s

Factory setting: 0.5 s

tT1

Trigger

Torch trigger operating mode

off / on

Factory setting: on

off

Operating welding torch without torch trigger
High frequency ignition is deactivated.

on

TIG 2-step or 4-step mode

1Gn

HF ignition

off / tHF / EHF / on

Factory setting: on

off

No HF ignition at the start of welding - welding started by contact ignition

tHF

The welding process is initiated by briefly touching the workpiece with the tungsten electrode. The high frequency ignition is performed after the set HF ignition delay time has elapsed.

EHF

Start with an external ignition device, e.g., plasma welding

on

HF ignition is activated

The HF ignition special indicator illuminates on the control panel when the "HF ignition" parameter is set to "on".



CAUTION!

Risk of injury due to an electric shock

Although Fronius devices comply with all the relevant standards, high frequency ignition can transmit a harmless but noticeable electric shock under certain circumstances.

- ▶ Use prescribed protective clothing, especially gloves!
- ▶ Only use suitable, completely intact, and undamaged TIG hosepacks!
- ▶ Do not work in damp or wet environments!
- ▶ Take special care when working on scaffolding, work platforms, in tight, difficult to access or exposed places, or when welding out-of-position!



HF ignition delay time

Time after touching the workpiece with the tungsten electrode after which the high frequency ignition takes place.

0.1 - 5.0 s

Factory setting: 1.0 s



Pulse TAC display

off / on

Factory setting: on

This menu item can be used to hide the pulsing and tacking parameters on the control panel in the welding parameter overview.



Ignition time out

Period of time until the safety cut-out following failed ignition

0.1 - 9.9 s

Factory setting: 5 s



Arc break monitoring

Period of time until the safety cut-out following an arc break

0.1 - 9.9 s

Factory setting: 1.0 s

IMPORTANT! Arc break monitoring is a safety function and cannot be deactivated.

A description of the arc break monitoring function can be found in the "TIG welding" section on page 58.



TIG Comfort Stop Sensibility - Comfort Stop sensitivity

The parameter is only available if the "Trigger" parameter is set to "off".

oFF / 0.6 - 3.5 V

Factory setting: 1.5 V

At the end of the welding process, an automatic shutdown of the welding current follows a significant increase of the arc length. This prevents the arc from having to be unnecessarily lengthened when lifting the TIG welding torch.

Process:

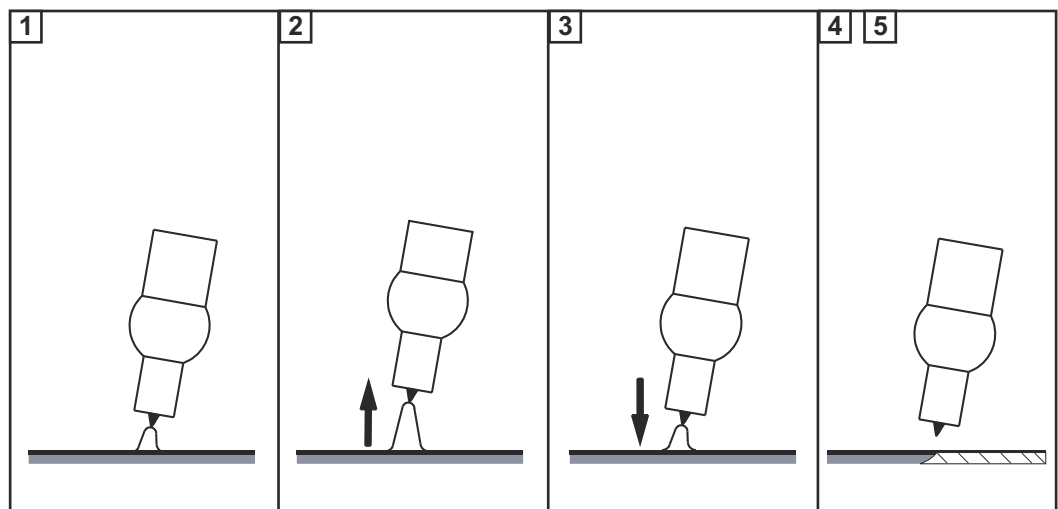

- 1 Welding
- 2 Briefly lift the welding torch at the end of welding

The arc lengthens significantly.

- 3 Lower the welding torch
 - The arc shortens significantly
 - The TIG Comfort Stop function has triggered

- 4 Maintain height of the welding torch
 - The welding current ramps down continuously (DownSlope).
 - The arc goes out.

IMPORTANT! The DownSlope is fixed and cannot be adjusted.

5 Lift the welding torch from the workpiece



Break voltage

For setting a voltage value at which the welding process may be ended by slightly raising the TIG welding torch.

The higher the break voltage value, the higher the arc can be raised.

The break voltage values for 2-step mode, 4-step mode, and operation with a foot-operated remote control are all stored together.

If the "tri" parameter (trigger - torch trigger operating mode) is set to "oFF", the values are stored separately.

10 - 45 V

Factory setting: 35 V (for 2-step and 4-step mode and operation with a foot-operated remote control)

Factory setting: 25 V (for trigger = oFF operation)



Main current changeover

on / off

Factory setting: on

on

After welding has started, an automatic selection of the main current I_1 takes place.

The main current I_1 can be adjusted immediately.

off

During welding, the last selected parameter remains selected.

The last selected parameter can be adjusted immediately.

No automatic selection of the main current I_1 takes place.

Parameters in the 2nd level Setup menu

The following parameters are available through the second level of the Setup menu:



System active time

To display the welding duration (the time during which welding has taken place)

The complete welding duration is divided across several displays and can be viewed by turning the dial.

Displayed in h / min. / sec.



System on time

For displaying the operating duration (count begins as soon as the device is switched on)

The complete operating duration is divided across several displays and can be accessed by turning the dial.

Displayed in h / min. / sec.



Fuse

To display/set the fuse being used

At 230 V: 10, 13, 16 A / off *

At 120 V: 15, 16, 20 A * / off *

* Only on Artis 170 MV / Artis 210 MV

Factory setting:

16 A at a mains voltage of 230 V

16 A at a mains voltage of 120 V

If a fuse is set on the welding system, the welding system will limit the current drawn from the grid, which prevents an immediate tripping of the automatic circuit breaker.

Max. welding current depending on the selected fuse Duty cycle = 40%

Device	Mains voltage	Fuse	Max. TIG welding current	Max. electrode welding current
Artis 170	230 V	10 A	170 A	125 A
		13 A	170 A	150 A
		16 A	170 A	150 A
		oFF *	170 A	150 A
Artis 170 MV	120 V **	15 A	130 A	85 A
		16 A	140 A	95 A
		20 A *	140 A	100 A
		oFF *	140 A	100 A
Artis 210	230 V	10 A	180 A	125 A
		13 A	200 A	150 A
		16 A	210 A	150 A
		oFF *	210 A	150 A
Artis 210 MV	120 V **	15 A	130 A	85 A
		16 A	140 A	95 A
		20 A *	170 A	120 A
		oFF *	170 A	120 A

- * Only on Artis 170 MV / Artis 210 MV
 - ** Depending on the trigger characteristics of the automatic circuit breaker used, the full duty cycle of 40% may not be reached with a 120 V grid (for example, USA circuit breaker type CH 15% D.C.).
-



Software version

The complete version number of the current software is divided across several displays and can be viewed by turning the dial.



Automatic shutdown

off / 5 - 60 minutes

Factory setting: off

If the device is not used or operated within a set period of time, it automatically switches into Standby mode.

Pressing a button on the control panel switches off Standby mode - the device is now ready for welding.

Rod Electrode Setup Menu

Parameters in the stick electrode Setup menu

The following parameters are available through the stick electrode Setup menu:

A green rectangular display showing the text 'HCU' in yellow digital characters.

HotStart current

1 - 200%

Factory setting: 130%

A green rectangular display showing the text 'Hti' in yellow digital characters.

Starting current duration

0.1 - 2.0 s

Factory setting: 0.5 s

A green rectangular display showing the text 'Str' in yellow digital characters.

Start ramp

To activate/deactivate the start ramp for the manual metal arc welding ignition process

on / off

Factory setting: on (activated)

A green rectangular display showing the text 'F-P' in yellow digital characters.

Pulse frequency

for pulse welding with stick electrodes

off / 0.2 - 990 Hz

Factory setting: off

The set pulse frequency is also applied for the lowering current.

The pulsing special indicator illuminates on the control panel if a value for the pulse frequency has been entered.

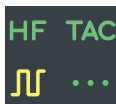
A black rectangular display showing 'HF TAC' in green text above a yellow sine wave symbol and three dots.A green rectangular display showing the text 'AST' in yellow digital characters.

Anti-stick

on / off

Factory setting: on

As the arc becomes shorter, the welding voltage may also fall so that the stick electrode is more likely to stick to the workpiece. This may also cause the stick electrode to burn out.

Electrode burn-out is prevented by activating the anti-stick function. If the stick electrode begins to stick, the welding system immediately switches the welding current off. The welding process can be resumed without problems once the stick electrode has been detached from the workpiece.

A green rectangular box containing the letters 'CEL' in a yellow, digital-style font.

CEL mode

on / off

Factory setting: off

To weld with Cel electrodes, the parameter must be set to "on".

A green rectangular box containing the letters 'dyn' in a yellow, digital-style font.

Dynamic correction

To optimize the welding result

0 - 100

Factory setting: 20

0

Softer and low-spatter arc

100

Harder and more stable arc

At the moment of droplet transfer or in event of a short circuit, a short-term increase in the amperage will occur. To maintain a stable arc, the welding current temporarily rises. If the stick electrode is at risk of sinking into the weld pool, this action prevents the weld pool from solidifying, as well as reducing the duration of the arc's short circuit. The risk of the stick electrode sticking is therefore largely ruled out.

A green rectangular box containing the letters 'Uco' in a yellow, digital-style font.

Break voltage

Limitation of the welding voltage

25 - 90 V

Factory setting: 45 V

In principle, the arc length depends on the welding voltage. To end the welding process, a significant lifting of the stick electrode is usually required. The "Uco" parameter allows the welding voltage to be limited to a value, which permits the welding process to be ended by only slightly lifting the stick electrode.

IMPORTANT! If the welding process regularly comes to an unintentional end, set the break voltage parameter to a higher value.

A green rectangular box containing the letters 'FAC' in a yellow, digital-style font.

Reset welding system

No / YES / ALL

Factory setting: No

YES:

Only the currently active welding mode is reset (2T / 4T / trigger = oFF / STICK / STICK CEL / foot-operated remote control)

ALL:

All operating modes are reset.



2nd level Setup menu

For viewing "system active time", "system on time", "fuse" and "software version" parameters

For setting the "time shut down" parameter

For more details about the 2nd level Setup menu, see page [78](#).

Troubleshooting and Maintenance

Troubleshooting

General

The welding system is equipped with an intelligent safety system, which completely negates the need for fuses. After correcting a possible error, the welding system can be properly operated again without having to change any fuses.

Safety

WARNING!

Danger from incorrect operation and work that is not carried out properly.

This can result in serious personal injury and damage to property.

- ▶ All the work and functions described in this document must only be carried out by technically trained and qualified personnel.
 - ▶ Read and understand this document in full.
 - ▶ Read and understand all safety rules and user documentation for this equipment and all system components.
-

WARNING!

Danger from electrical current.

This can result in serious personal injury and damage to property.

- ▶ Before starting work, switch off all the devices and components involved and disconnect them from the grid.
 - ▶ Secure all devices and components involved so they cannot be switched back on.
 - ▶ After opening the device, use a suitable measuring instrument to check that electrically charged components (such as capacitors) have been discharged.
-

WARNING!

Danger due to insufficient ground conductor connection.

This can result in serious personal injury and damage to property.

- ▶ The housing screws provide a suitable ground conductor connection for grounding the housing.
 - ▶ The housing screws must not under any circumstances be replaced by other screws without a reliable ground conductor connection.
-

Displayed Faults

High temperature

"hot" is shown in the display

Cause: Operating temperature is too high

Remedy: Leave the device to cool (Do not switch off the device - the fan will cool the device)

Service messages

If "Err" is displayed on the left display and an error code is displayed on the right display, this is an internal service code for the welding system.

Example:



There can be multiple error codes. These appear by turning the dial.



Take note of all displayed error codes as well as the serial number and configuration of the welding system, and then contact the service center with a detailed error description.

Err | 1-3 / 11 / 15 / 21 / 33-35 / 37-40 / 42-44 / 46-52

Cause: Power module error

Remedy: Contact the service team

Err | 4

Cause: Open circuit voltage has not been reached:
Electrode is in contact with the component/hardware defect

Remedy: Remove the electrode support from the component. If the service code continues to be displayed, contact service team

Err | 5 / 6 / 12 / 14

Cause: System start failure

Remedy: Turn device off and on again. If this happens multiple times, inform service team

Err | 10

Cause: Overvoltage at the current socket ($> 113 V_{DC}$)

Remedy: Contact the service team

Err | 16 / 17 / 18

Cause: Memory error

Remedy: Contact service team;

Err 16: press dial to acknowledge service message

NOTE!

For standard device variants, acknowledging the service message does not have an effect on the welding system's range of functions.

For all other device variants (TIG, etc.), the welding system only offers a restricted range of functions after acknowledgment. Inform the service team to re-establish the full range of functions.

Err | 19

Cause: Overtemperature or undertemperature

Remedy: Operate device at permitted ambient temperature. For more information about environmental conditions see "Environmental Conditions" in the "Safety Rules" section

Err | 20

Cause: Improper use of the device

Remedy: Only use the device in accordance with the intended purpose

Err | 22

Cause: Welding current set too high

Remedy: Ensure that the welding system is being operated at the correct mains voltage; ensure the correct fuse is set; set a lower welding current

Err | 37

Cause: Mains voltage exceeds admissible limits

Remedy: Immediately pull out the mains plug and ensure that the welding system is being operated at the correct mains voltage

Err | 36 / 41 / 45

Cause: Mains voltage is outside of the tolerance or mains output is insufficient for the connected device(s)

Remedy: Ensure that the welding system is being operated at the correct mains voltage; ensure the correct fuse is set

Err | 65-75

Cause: Error in communicating with the display

Remedy: Turn device off and on again / inform service team if this happens multiple times

r | Err

Cause: Error while determining the welding circuit resistance

Remedy: Inspect torch hosepack, welding torch, and grounding cable for damage;
check connections and contacts;
check the cleanliness of the workpiece surface.

For more information on determining the welding circuit resistance, refer to the 2nd TIG menu (see page [74](#)).

No Function

Device cannot be switched on

Cause: Defective power switch

Remedy: Inform service team

No welding current

The welding system is switched on, display for selected process illuminates

Cause: Welding power-lead connections interrupted

Remedy: Correctly establish welding power-lead connections

Cause: Poor grounding or no grounding at all

Remedy: Establish a connection with the workpiece

Cause: Power cable in the welding torch or electrode holder interrupted

Remedy: Replace welding torch or electrode holder

No welding current

Switch on device, display illuminates for selected process, overtemperature display illuminates

Cause: Duty cycle exceeded - device overloaded - fan running

Remedy: Observe duty cycle

Cause: Thermal automatic circuit breaker has shut down the device

Remedy: Wait for device to cool down (do not switch off the device - the fan will cool the device); the welding system will switch on again automatically after a short time

Cause: Fan in the welding system defective

Remedy: Contact After-Sales Service

Cause: Cooling air supply is insufficient

Remedy: Ensure there is a sufficient air supply

Cause: Air filter is dirty

Remedy: Clean air filter

Cause: Power module error

Remedy: Switch the device off and then on again
If this error persists, inform service team

Inadequate function

Poor ignition properties during manual metal arc welding

Cause: The wrong process has been selected

Remedy: Select "manual metal arc welding" or "manual metal arc welding with Cel electrodes" process

Cause: Starting current too low; electrode remains stuck during ignition process

Remedy: Raise starting current with HotStart function

Cause: Starting current too high; electrode burns too quickly during ignition process or spatters strongly

Remedy: Reduce starting current with SoftStart function

Arc occasionally breaks during the welding process

Cause: Break voltage (Uco) is set too low

Remedy: Raise the break voltage (Uco) in the Setup menu

Cause: Voltage of the electrode too high (e.g. grooved electrode)

Remedy: Use alternative electrode if possible or use power source with higher welding power

Rod electrode tends to stick to the workpiece

Cause: Value for dynamic parameter (manual metal arc welding) set too low

Remedy: Set a higher value for dynamic parameter

Poor-quality weld property

(strong spattering)

Cause: Incorrect polarity of the electrode

Remedy: Reverse the polarity of the electrode (observe manufacturer guidelines)

Cause: Poor ground earth connection

Remedy: Attach earthing clamps directly to the workpiece

Cause: Non-viable setup setting for the selected process

Remedy: Optimize the setting for the selected process in the Setup menu

Tungsten electrode melts

Tungsten inclusions in the parent material during the ignition phase

Cause: Incorrect polarity of the tungsten electrode

Remedy: Connect TIG welding torch to the (-) current socket

Cause: Incorrect shielding gas, no shielding gas

Remedy: Use inert shielding gas (argon)

Service, maintenance and disposal

General

The welding system only requires a minimum of service and maintenance under normal operating conditions. However, several points must be observed in order for the welding system to remain operational for years to come.

Safety

WARNING!

Danger from electrical current.

This can result in serious personal injury and damage to property.

- ▶ Before starting work, switch off all the devices and components involved and disconnect them from the grid.
 - ▶ Secure all devices and components involved so they cannot be switched back on.
 - ▶ After opening the device, use a suitable measuring instrument to check that electrically charged components (such as capacitors) have been discharged.
-

WARNING!

Danger from incorrect operation and work that is not carried out properly.

This can result in serious personal injury and damage to property.

- ▶ All the work and functions described in this document must only be carried out by technically trained and qualified personnel.
 - ▶ Read and understand this document in full.
 - ▶ Read and understand all safety rules and user documentation for this equipment and all system components.
-

At every start-up

- Check mains plug and mains cable, as well as the welding torch, interconnecting hosepack, and ground earth connection for damage
- Check if the all-round clearance of the device is 0.5 m (1 ft. 8 in.) so that cooling air can circulate unimpeded

NOTE!

Air inlet and outlet openings must not be blocked or even partially covered.

**Maintenance
every two
months**

Clean air filter:

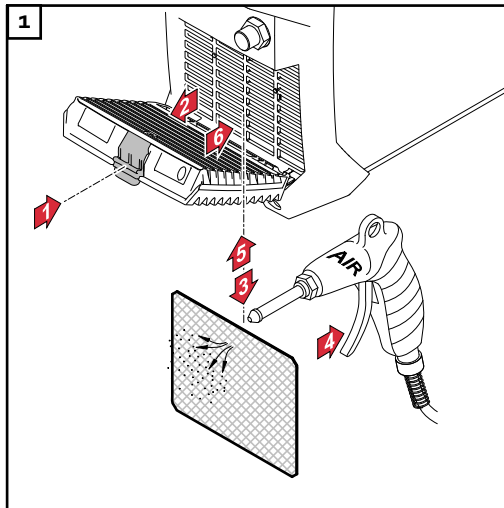

Disposal

Disposal must only be carried out in accordance with the section of the same name in the "Safety rules" chapter.

Appendix

Average consumption values during welding

Average shielding gas consumption during TIG welding

Gas nozzle size	4	5	6	7	8	10
Average consumption	6 l/min	8 l/min	10 l/min	12 l/min	12 l/min	15 l/min

Technical data

Special Voltage For devices designed for special voltages, the technical data on the rating plate applies.

Artis 170 EF, Artis 170 np	Mains voltage U_1	1 x 230 V
	Max. effective primary current ($I_{1\text{eff}}$)	11.3 A
	Max. primary current ($I_{1\text{max}}$)	15.0 A
	Mains voltage tolerance	-30% / +15%
	Mains frequency	50/60 Hz
	Mains fuse	16 A slow-blow
	Mains connection ¹⁾	Z_{max} at PCC ³⁾ = 356 MOhm
	Primary continuous power (100% D.C. 2))	2.7 kVA
	Max. apparent power $S_{1\text{max}}$	3.5 kVA
	Cos phi	0.99
	Welding current range	
	TIG	3 - 170 A
	MMA	10 - 150 A
	Welding current at 10 min / 40 °C (104 °F), $U_1 = 230$ V	
	TIG	40% D.C. ²⁾ / 170 A 60% D.C. ²⁾ / 155 A 100% D.C. ²⁾ / 140 A
	MMA	40% D.C. ²⁾ / 150 A 60% D.C. ²⁾ / 120 A 100% D.C. ²⁾ / 110 A
	Open circuit voltage (pulsed)	
	TIG	35 V
	MMA	101 V
	Working voltage	
	TIG	10.1 - 16.8 V
MMA	20.4 - 26.0 V	
Striking voltage U_p	9.0 kV	
	The arc ignition device is suitable for manual operation	
Protection class	Protection class 23	
Type of cooling	AF	

Insulation class	A
EMC emission class (according to EN/IEC 60974-10)	A
Overvoltage category	III
Pollution degree according to IEC60664	3
Ambient temperature	-10 °C - +40 °C / +14 °F - +104 °F
Storage temperature	-25 °C - +55 °C / -13 °F - +131 °F
Dimensions l x w x h	435 x 160 x 310 mm / 17.1 x 6.3 x 12.2 in.
Weight	9.8 kg / 21.61 lb.
Mark of conformity	CE
Safety symbols	S
Max. shielding gas pressure	5 bar/73 psi
Noise emissions (L _{WA})	68.0 dB(A)
Idle state power consumption at 230 V	15 W
Energy efficiency of the welding system at 150 A / 26 V	88%

**Artis 170 XT/B,
Artis 170 XT/np**

Mains voltage	1 x 120 V / 1 x 230 V
Max. effective primary current ($I_{1\text{eff}}$)	
1 x 120 V	14.5 A
1 x 230 V	11.3 A
Max. primary current ($I_{1\text{max}}$)	
1 x 120 V	22.7 A
1 x 230 V	15.0 A
Mains voltage tolerance	
1 x 120 V	-20% / +15%
1 x 230 V	-30% / +15%
Mains frequency	50/60 Hz
Mains fuse	
1 x 120 V	20 A slow-blow
1 x 230 V	16 A slow-blow
Mains connection ¹⁾	Z_{max} at PCC ³⁾ = 356 MOhm
Primary continuous power (100% D.C. ²⁾)	
1 x 120 V	1.8 kVA
1 x 230 V	2.7 kVA
Max. apparent power $S_{1\text{max}}$	
1 x 120 V	2.8 kVA
1 x 230 V	3.5 kVA
Cos phi	0.99
Welding current range	
TIG / 1 x 120 V	3 - 140 A
TIG / 1 x 230 V	3 - 170 A
Stick electrode / 1 x 120 V	10 - 100 A
Stick electrode / 1 x 230 V	10 - 150 A
Welding current at 10 min / 40 °C (104 °F)	
TIG / 1 x 120 V	40% D.C. ²⁾ / 140 A 60% D.C. ²⁾ / 120 A 100% D.C. ²⁾ / 100 A
TIG / 1 x 230 V	40% D.C. ²⁾ / 170 A 60% D.C. ²⁾ / 155 A 100% D.C. ²⁾ / 140 A
Stick electrode / 1 x 120 V	40% D.C. ²⁾ / 100 A 60% D.C. ²⁾ / 90 A 100% D.C. ²⁾ / 80 A

Stick electrode / 1 x 230 V	40% D.C. ²⁾ / 150 A 60% D.C. ²⁾ / 120 A 100% D.C. ²⁾ / 110 A
Open circuit voltage (pulsed)	
TIG	35 V
MMA	101 V
Working voltage	
TIG / 1 x 120 V	10.1 - 15.6 V
TIG / 1 x 230 V	10.5 - 16.8 V
Stick electrode / 1 x 120 V	20.4 - 24.0 V
Stick electrode / 1 x 230 V	20.4 - 26.0 V
Striking voltage U_p	9 kV
	The arc ignition device is suitable for manual operation
Protection class	Protection class 23
Type of cooling	AF
Insulation class	A
EMC emission class (according to EN/IEC 60974-10)	A
Overvoltage category	III
Pollution degree according to IEC60664	3
Ambient temperature	-10 °C - +40 °C / +14 °F - +104 °F
Storage temperature	-25 °C - +55 °C / -13 °F - +131 °F
Dimensions l x w x h	435 x 160 x 310 mm / 17.1 x 6.3 x 12.2 in.
Weight	9.8 kg / 21.61 lb.
Mark of conformity	CE, CSA
Safety symbols	S
Max. shielding gas pressure	5 bar/73 psi
Noise emissions (L_{WA})	68.0 dB(A)
Idle state power consumption at 230 V	15 W
Energy efficiency of the welding system at 150 A / 26 V	88%

**Artis 210 EF,
Artis 210 np**

Mains voltage U_1	1 x 230 V
Max. effective primary current ($I_{1\text{eff}}$)	13.5 A
Max. primary current ($I_{1\text{max}}$)	20.0 A
Mains voltage tolerance	-30% / +15%
Mains frequency	50/60 Hz
Mains fuse	16 A slow-blow
Mains connection ¹⁾	Z_{max} at PCC ³⁾ = 261 MOhm
Primary continuous power (100% D.C. 2))	3.2 kVA
Max. apparent power $S_{1\text{max}}$	4.6 kVA
Cos phi	0.99
Welding current range	
TIG	3 - 210 A
MMA	10 - 180 A
Welding current at 10 min / 40 °C (104 °F), $U_1 = 230$ V	
TIG	40% D.C. ²⁾ / 210 A 60% D.C. ²⁾ / 185 A 100% D.C. ²⁾ / 160 A
MMA	40% D.C. ²⁾ / 180 A 60% D.C. ²⁾ / 150 A 100% D.C. ²⁾ / 120 A
Open circuit voltage (pulsed)	
TIG	35 V
MMA	101 V
Working voltage	
TIG	10.1 - 18.4 V
MMA	20.4 - 27.2 V
Striking voltage U_p	9.0 kV
	The arc ignition device is suitable for manual operation
Protection class	Protection class 23
Type of cooling	AF
Insulation class	A
EMC emission class (according to EN/IEC 60974-10)	A
Oversvoltage category	III
Pollution degree according to IEC60664	3

Ambient temperature	-10 °C - +40 °C / +14 °F - +104 °F
Storage temperature	-25 °C - +55 °C / -13 °F - +131 °F
Dimensions l x w x h	435 x 160 x 310 mm / 17.1 x 6.3 x 12.2 in.
Weight	9.8 kg / 21.61 lb.
Mark of conformity	CE
Safety symbols	S
Max. shielding gas pressure	5 bar/73 psi
Noise emissions (L _{WA})	68.0 dB(A)
Idle state power consumption at 230 V	15 W
Energy efficiency of the welding system at 180 A / 27.2 V	88%

**Artis 210 XT/B,
Artis 210 XT/np**

Mains voltage	1 x 120 V / 1 x 230 V
Max. effective primary current ($I_{1\text{eff}}$)	
1 x 120 V	18.0 A
1 x 230 V	13.5 A
Max. primary current ($I_{1\text{max}}$)	
1 x 120 V	29.0 A
1 x 230 V	20.0 A
Mains voltage tolerance	
1 x 120 V	-20% / +15%
1 x 230 V	-30% / +15%
Mains frequency	50/60 Hz
Mains fuse	
1 x 120 V	20 A slow-blow
1 x 230 V	16 A slow-blow
Mains connection ¹⁾	Z_{max} at PCC ³⁾ = 261 MOhm
Primary continuous power (100% D.C. ²⁾)	
1 x 120 V	2.2 kVA
1 x 230 V	3.2 kVA
Max. apparent power $S_{1\text{max}}$	
1 x 120 V	3.5 kVA
1 x 230 V	4.6 kVA
Cos phi	0.99
Welding current range	
TIG / 1 x 120 V	3 - 170 A
TIG / 1 x 230 V	3 - 210 A
Stick electrode / 1 x 120 V	10 - 120 A
Stick electrode / 1 x 230 V	10 - 180 A
Welding current at 10 min / 40 °C (104 °F)	
TIG / 1 x 120 V	40% D.C. ²⁾ / 170 A 60% D.C. ²⁾ / 150 A 100% D.C. ²⁾ / 120 A
TIG / 1 x 230 V	40% D.C. ²⁾ / 210 A 60% D.C. ²⁾ / 185 A 100% D.C. ²⁾ / 160 A
Stick electrode / 1 x 120 V	40% D.C. ²⁾ / 120 A 60% D.C. ²⁾ / 100 A 100% D.C. ²⁾ / 90 A

Stick electrode / 1 x 230 V	40% D.C. ²⁾ / 180 A 60% D.C. ²⁾ / 150 A 100% D.C. ²⁾ / 120 A
Open circuit voltage (pulsed)	
TIG	35 V
MMA	101 V
Working voltage	
TIG / 1 x 120 V	10.1 - 16.8 V
TIG / 1 x 230 V	10.1 - 18.4 V
Stick electrode / 1 x 120 V	20.4 - 24.8 V
Stick electrode / 1 x 230 V	20.4 - 27.2 V
Striking voltage U _p	9 kV
The arc ignition device is suitable for manual operation	
Protection class	Protection class 23
Type of cooling	AF
Insulation class	A
EMC emission class (according to EN/IEC 60974-10)	A
Overvoltage category	III
Pollution degree according to IEC60664	3
Ambient temperature	-10 °C - +40 °C / +14 °F - +104 °F
Storage temperature	-25 °C - +55 °C / -13 °F - +131 °F
Dimensions l x w x h	435 x 160 x 310 mm / 17.1 x 6.3 x 12.2 in.
Weight	9.9 kg / 21.8 lb.
Mark of conformity	CE, CSA
Safety symbols	S
Max. shielding gas pressure	5 bar/73 psi
Noise emissions (L _{WA})	68.0 dB(A)
Idle state power consumption at 230 V	15 W
Energy efficiency of the welding system at 180 A / 27.2 V	88%

Explanation of footnotes

/EF	Welding system with mains cable fitted
/np	Welding system with mains cable fitted and without plug for the public grid
/B	Welding system with mains cable to plug in

- 1) On a public grid with 230 V and 50 Hz
- 2) D.C. = duty cycle
- 3) PCC = interface to the public grid

Overview with critical raw materials, year of production of the device

Overview with critical raw materials:

An overview of which critical raw materials are contained in this device can be found at the following Internet address.

www.fronius.com/en/about-fronius/sustainability.

To calculate the year of production of the device:

- Each device is provided with a serial number
- The serial number consists of 8 digits - for example 28020099
- The first two digits give the number from which the year of production of the device can be calculated
- This figure minus 11 gives the year of production
 - For example: Serial number = 28020065, calculation of the year of production = 28 - 11 = 17, year of production = 2017



Fronius International GmbH

Froniusstraße 1
4643 Pettenbach
Austria
contact@fronius.com
www.fronius.com

At www.fronius.com/contact you will find the contact details
of all Fronius subsidiaries and Sales & Service Partners.